

**Technology Application for  
Underground Accidents  
in Coal Mines**

**Zhang Tiegang  
Academician**

**China Academy of Engineering**

## Technology Application for Underground Accidents in Coal Mines ( mine emergency rescue )

The purpose of mine emergency rescue is to eliminate accident's influence in the budding period or prevent it from getting worse, and minimize the loss of lives and properties to the lowest level.

the characteristics of accidents' occurrence: 1. spontaneous 2. differentiated place 3. under cover 4. pressing 5. easy to change

the accident scene is like a battle field. The on site commander is the key player to the success of the rescue operation. So he has to be sober minded, experienced, determined and make right decisions.



# Mine Emergency Rescue

## Fire Extinguishing

There are dozens of underground fire extinguishing methods, which can be clarified as six criteria, grouting, pressure balance, Fire-retardant Lime-Gel, inert gas, sealing.

### 1. Grouting injection

grouting injection method, by mixing sienna, lime ( powder coal ash ) to a certain density grout, and then inject it via mechanical means to the internal area of the fire zone, filling the space of the fire zone. It can on one hand reduce the temperature through vaporization bringing some heat, and isolate the fire zone from oxygen on the other hand, thus to realize the purpose of extinguishing fire through temperature reduction and oxygen isolation.

# Mine Emergency Rescue

## Fire Extinguishing

the main ingredient of powder coal ash is CaO. By adding water, it will produce Ca(OH)<sub>2</sub>, which can have chemical reaction with SO<sub>2</sub>、SO<sub>3</sub>、CO<sub>2</sub>.the production of the reaction process will form a dense oxygen isolation belt on the grout, which can cut off the air convection and oxygen flow, as to realize the effect of fire extinguishing.

main chemical reaction :

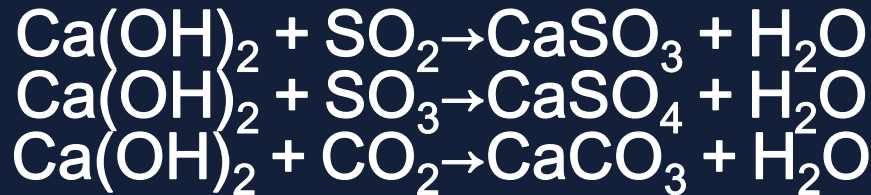

# Mine Emergency Rescue

## Fire Extinguishing

there are a certain amount of active  $\text{SiO}_2$  and  $\text{Al}_2\text{O}_3$  in sienna. Active  $\text{SiO}_2$  and  $\text{Al}_2\text{O}_3$  have large inner surface.  $\text{OH}^-$  can easily breach and disaggregate  $\text{Si-O}$  and  $\text{Al-O}$ , and producing gelatin. Active  $\text{SiO}_2$  and  $\text{Al}_2\text{O}_3$  by having chemical reaction with  $\text{Ca(OH)}_2$ , can produce hydrate calcium silicate and hydrate aluminum silicate gelatin, which are hydraulic, water resistant, with relative strength, and have good infiltration resistance.

main chemical reaction :

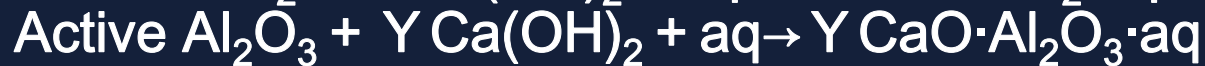
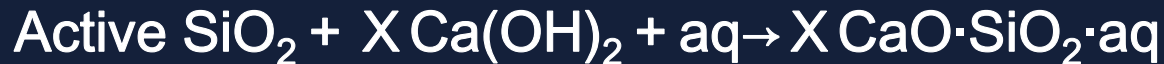

# Mine Emergency Rescue

## Fire Extinguishing

### 2、 Fire-retardant

#### a、 normal fire-retardant

major fire-retardant used in coal mine :  $\text{CaCl}_2$ ,  $\text{MgCl}_2$ ,  $\text{BaCl}_2$ ,  $\text{AgCl}_3$ ,  $\text{FeCl}_2$ ,  $\text{kCl}$ ,  $\text{NaCl}$ ,  $\text{ZnCl}_2$ ,  $\text{CaSO}_4$ ,  $\text{MgSO}_4$ ,  $\text{Na}_2\text{SO}_4$ ,  $\text{NaHPO}_4$ ,  $\text{Ca(OH)}_2$ ,  $\text{P}_2\text{O}_5$ ,  $\text{KOH}$ ,  $\text{H}_3\text{BO}_3$ ,  $\text{Na}_2\text{O}\cdot n\text{SiO}_2$  etc. , while  $\text{CaCl}_2 \cdot 5\text{H}_2\text{O}$ ,  $\text{MgCl}_2 \cdot 6\text{H}_2\text{O}$ ,  $\text{ZnCl}_2$ ,  $\text{AgCl}_3$ ,  $\text{P}_2\text{O}_5$  have good effect, abundant in supply, convenient for reserving and transportation, and cheap price.

# Mine Emergency Rescue

## Fire Extinguishing

### 2、Fire-retardant

#### b、gelatin

gelatin is produced by mixing basic material (water glass), accelerating agent (  $\text{CaHCO}_3$  ), and reinforcing agent, with water to a certain proportion. The main reaction :



the substance of gelatin is actually a form of existence of high dense silicic acid absorbing water, with water accounting for over 90%. Before forming into gelatin, it was transparent liquid, being quite good in fluidity, when its viscosity is like water. After shaping into gelatin, it will lose fluidity, turns to be accumulative. During the forming process, it needs absorbing a lot of heat, thus destroy the heat storage condition for spontaneous combustion of coal, and curb the spontaneous combustion and realize the effect of extinguishing fire.

# Mine Emergency Rescue

## Fire Extinguishing

### 2、Fire-retardant

#### c、new type fire extinguisher MEA

it is white powder solid featuring innocuous, flavourless with no pollution and erosion. The main ingredients of MEA are PANa, polypropylene acyl amic. By adding abio-retardant materials, it is manufactured into an environmentally friendly and high-tech fire retardant material through special technology. MEA in conjunction with water, can form fluid and osmotic colloid, which will soak the surface of coal instantly, and enwrap and adhere to the surface of coal face for a long period of time, effectively give away heat and reduce the temperature. The colloid under certain temperature, will cause the surface of coal coking and form a heat and air isolation coking belt, and enhance its fire resistant and extinguishing effect comprehensively.

# Mine Emergency Rescue

## Fire Extinguishing

---

### 3、nitrogen injection

fire extinguishing principal

#### a、suffocation

Injecting nitrogen into the sealed area to expel the air inside and reduce the concentration of oxygen, hence suffocate the source of fire.

#### b、explosion control

Nitrogen injected can reduce the concentration of combustible gas and oxygen, forming inert gas, preventing the mixture from explosion.

#### c、cooling

by directly injecting hydraulic nitrogen or cool nitrogen for extinguishing fire, it can cool the source of the fire instantly, and accelerate the process of extinguishing the fire source.  $N_2+O_2=2NO$

$\Delta H'_n=90.37KJ/mol$

---

# Mine Emergency Rescue

## Fire Extinguishing

---

### 4、 sealing

seal the intake and outtake airways, cut off the airflow, and isolate oxygen supply, hence extinguish the fire.

### 5、 pressure balance

adjusting pressure technology was firstly widely applied in some countries in Europe. It has been promoted and widely used in China in recent years. adjusting pressure is to use ventilation measures to adjust the wind pressure difference of the two ends of leaking airways, and minimize the difference to zero, so as to reduce or prevent wind leakage, curb and control the heating and spontaneous combustion of coal of the controlled area, contain the development of fire influence of the area, and expedite the inert suffocation of the sealing area. The is usually referred to as pressure balance fire extinguishing technology.

---

# Mine Emergency Rescue

## Fire Extinguishing

---

Pressure balance :

### 1、 increase pressure to pressure balance

when there is a minus  $\Delta H$  pressure difference for wind leakage, in which case the pressure in the working face  $H_e$  is  $\Delta H$  less than the pressure at the wind leakage place  $H_i$ , in order to reduce the wind leakage to the working face, try increasing the pressure  $H_{e0}$  of the balance place of the working face by  $\Delta H$  to realize balance.

Increasing pressure to pressure balance in negative pressure system:

In the extractable ventilation system, when there is internal leakage, the pressure of the balance point at working face  $H_{e0}$  will always remain negative even after increasing pressure. The difference  $\Delta H$  will approach zero.

---

# Mine Emergency Rescue

## Fire Extinguishing

---

### 2 、 reduce pressure to pressure balance

The main pressure difference  $\Delta H$  remains positive. When the pressure  $H_e$  at the working face is about  $\Delta H$  higher than that  $H_i$  of the main leaking point, in order to decrease the pressure at the working face, try to decrease the pressure  $H_{e0}$  of the balance point by  $\Delta H$ . While in forced ventilation, when there is internal leakage, the pressure of the balance point  $H_{e0}$  at the working face will always remain positive after decreasing pressure. The difference  $\Delta H$  will approach zero.

---

# Mine Emergency Rescue

## Fire Extinguishing

### Pressure balance measures

#### 1、 Adjust ventilation regulating window to realize pressure balance

This is mainly for local pressure balance adjustment for both increasing and decreasing pressure.

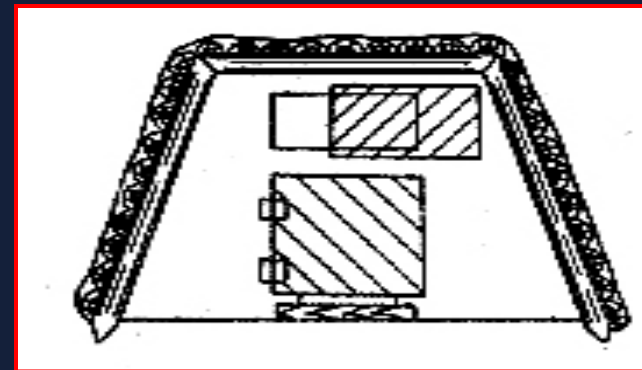

# Mine Emergency Rescue Fire Extinguishing

## 2、Auxiliary ventilation blower adjusting pressure balance

Applying for local pressure balance adjustment, for both increasing and decreasing pressure.

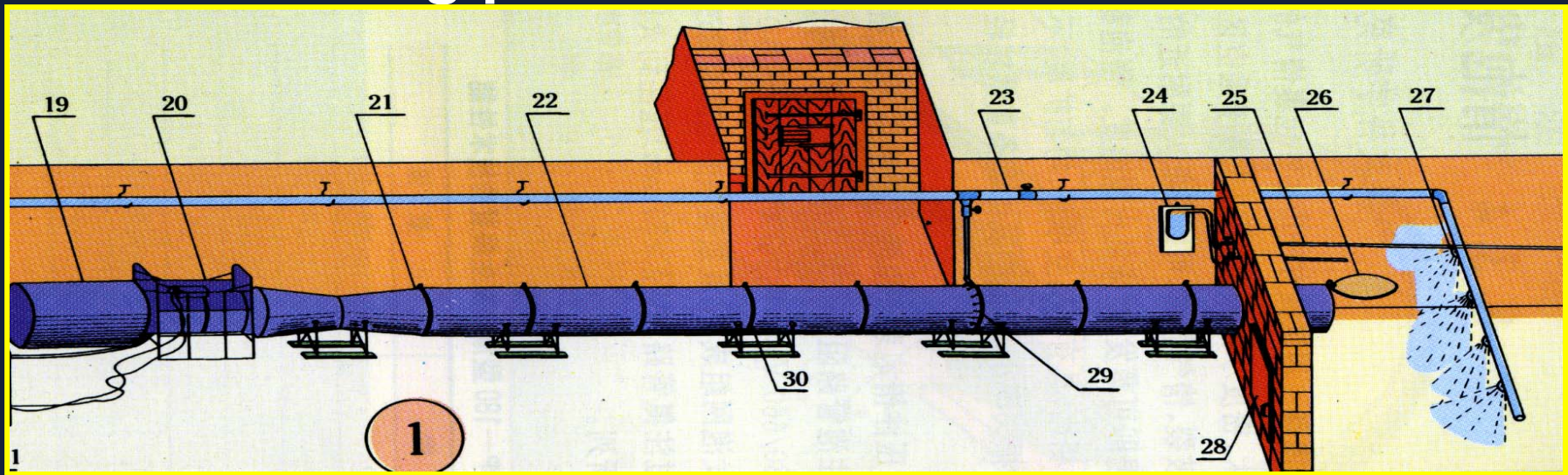

# Mine Emergency Rescue

## Fire Extinguishing

---

3、 Ventilation regulating window----  
auxiliary ventilation blower joint  
adjustment

---

# Mine Emergency Rescue Fire Extinguishing

ventilation regulating window pressure balance adjustment design

## 1、 Calculation of the opening area of the ventilation regulating window

the adjustment is equal to the pressure difference  $\Delta h$  between the main leaking point and the balance point.

$Q_t$ —the airflow volume after adjustment at the working face,  $m^3/min$

$\Delta h_{me}$ —adjustment , Pa

$Q$ —the airflow volume before adjustment ,  $m^3/min$

$\Delta h_{me} R_{me}$ —wind resistance along the working face to the adjustment point,  $\mu$

$$Q_t = \sqrt{Q^2 - \frac{\Delta h_{me} R_{me}}{R_w}}$$

$S_w$ —the opening area of the regulating window ,  $m^2$

$S$ —the interface of the drift wherein the regulating window is set ,  $m^2$

$h_w$ —the airflow resistance of the window , Pa

$R_w$ —wind resistance of the regulating window ,  $\mu$

$$h_w = (R_w + R_{me})Q_t^2 - R_{me}Q^2$$

$$S_w = \frac{Q_t \cdot S}{Q_t + 0.759S \sqrt{h_w}}$$

# Mine Emergency Rescue

## Fire Extinguishing

### 2、Setting the ventilation regulating window.

(1)location : for increasing pressure, usually locating within the stoppage line of the return airway

for decreasing pressure, usually locating within the stoppage line of the intake airway

In gassy mines, locating at the side driving area of the working face

(2)setting method : two ventilation doors or walls, with a distance of 8m to each other.

there is a rectangle opening with removable cover on the door or the wall, under which the automatic lock door is settled.

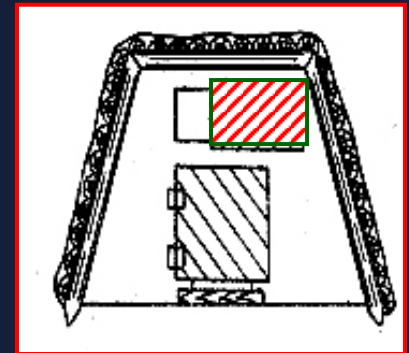

# Mine Emergency Rescue

Rescue case of gas explosion caused by fire accident.

Date : 2003年10月7日      hazard : fire

location : No.8 Mine of Pingdingshan Coal Group

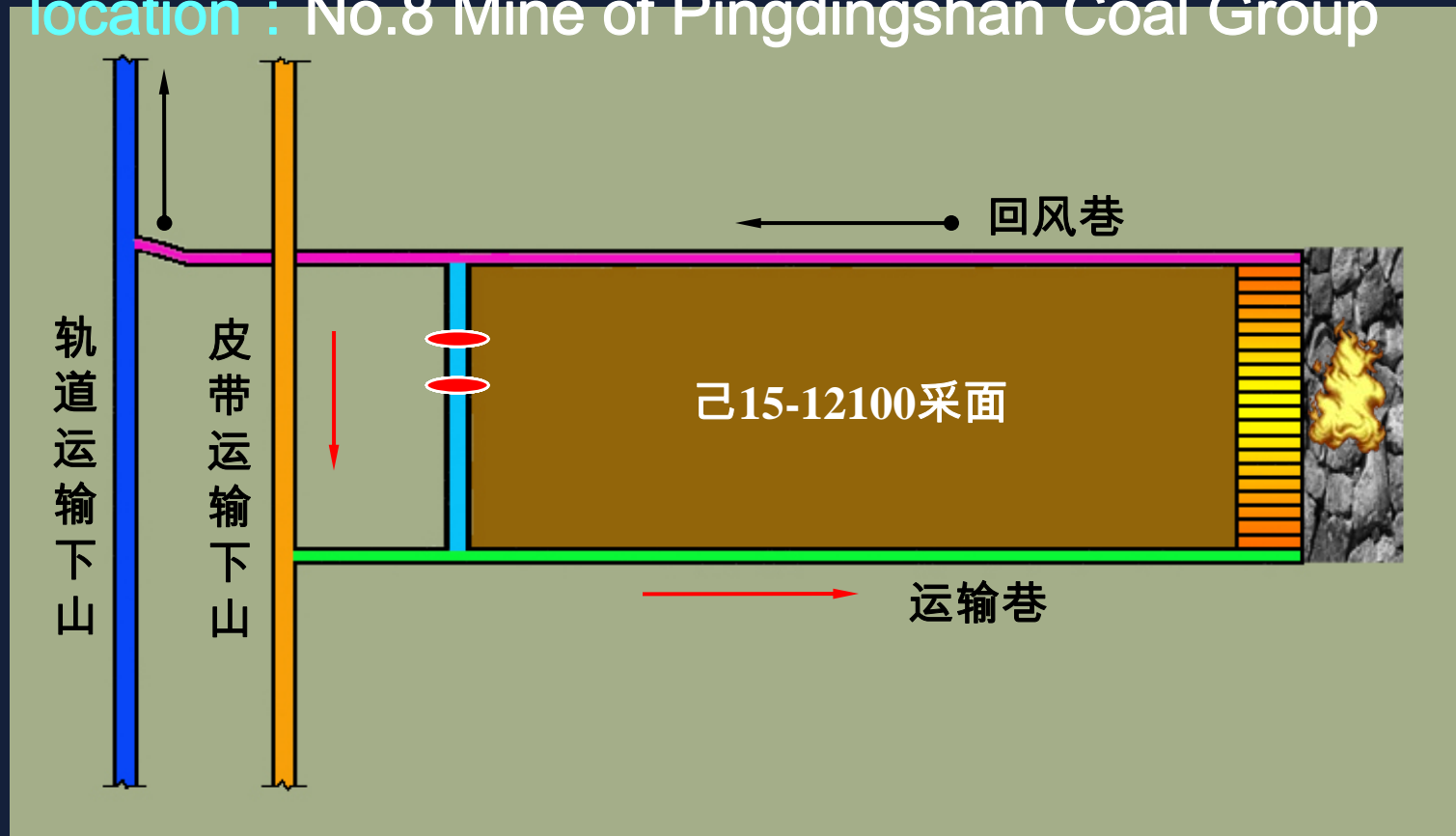

# Mine Emergency Rescue

Gas effusion prediction model at working face

$$q = K_v \left[ K_1 \cdot K_2 \cdot K_3 \cdot K_f (W_0 - W_c) + \sum_{i=1}^n W_{0i} \frac{m_i}{M} \eta_i \right]$$

$$q = K_v \frac{W_0 - W_c}{1 - K}$$

# Mine Emergency Rescue

Gas effusion prediction model at driving working face

$$G_1 = u \cdot v_1 \cdot V_0 \left[ \frac{\left( \frac{L_1}{v_1} \right)^{1-\beta} - 1}{1-\beta} + 1 \right]$$

$$q = \frac{G_1}{1+\alpha} \left[ \left( \frac{L_1}{v_1} \right)^{1+\alpha} - 1 \right]$$

# Mine Emergency Rescue

## Prediction of gas explosion time :

1、 Working space calculation :  $V=V_1+ V_2+ V_3=13500\text{m}^3$

$V_1$ -Working face space (  $\text{m}^3$  )  $V_1=h.b.L=3\times5\times167=2500\text{m}^3$

$V_2$ -Gob area (  $\text{m}^3$  )  $V_2=2V_1=5000\text{m}^3$

$V_3$ -Drifts (  $\text{m}^3$  )  $V_3=2.S.l=2\times10\times300=6000\text{m}^3$

2、 Gas net volume in the mining area under Gas explosion limit

$V_{\text{ch}_4}=V.i_1=13000\text{m}^3 \times 5\%=650\text{m}^3$   $i_1$ =Gas explosion limit concentration 0.05

3、 statistics measured from the airway that the absolute gas effusion volume at the mining face  $Q_1=5\text{m}^3/\text{min}$  when the short of external airflow was formed.

4、 The extended time under the explosion limit of the whole mining area

$$t_1 = \frac{V_{\text{CH}_4}}{Q_1} = \frac{650 \text{ m}^3}{5 \text{ m}^3 / \text{min}} = 130 \text{ min} = 2.02 \text{ 小时 ( 取 2 小时 )}$$

# Mine Emergency Rescue

- 5、 the total leaking volume under explosion limit ( 按 $r = 100\text{m}^3/\text{min}$ )
- $Q_2 = t_1 \cdot r = 130\text{min} \times 100 \text{ m}^3/\text{min} = 13000\text{m}^3$
- 6、 gas concentration after 130min

$$i_2 = \frac{V_{CH_4}}{V + Q_2} = \frac{650\text{m}^3}{13500\text{m}^3 + 13000\text{m}^3} = 0.0245$$

- 7、 the postponed period for gas explosion under leaking condition in sealing space.

$$t_2 = t_1 \cdot \frac{i_1}{i_2} = 130 \times \frac{0.05}{0.0245} = 265\text{min} = 4.4\text{小时} \quad (\text{取}4\text{小时})$$

# Mine Emergency Rescue

Rescue case of gas explosion  
caused by fire accident.

Design of auxiliary ventilation blower and adjusting  
pressure balance equipments

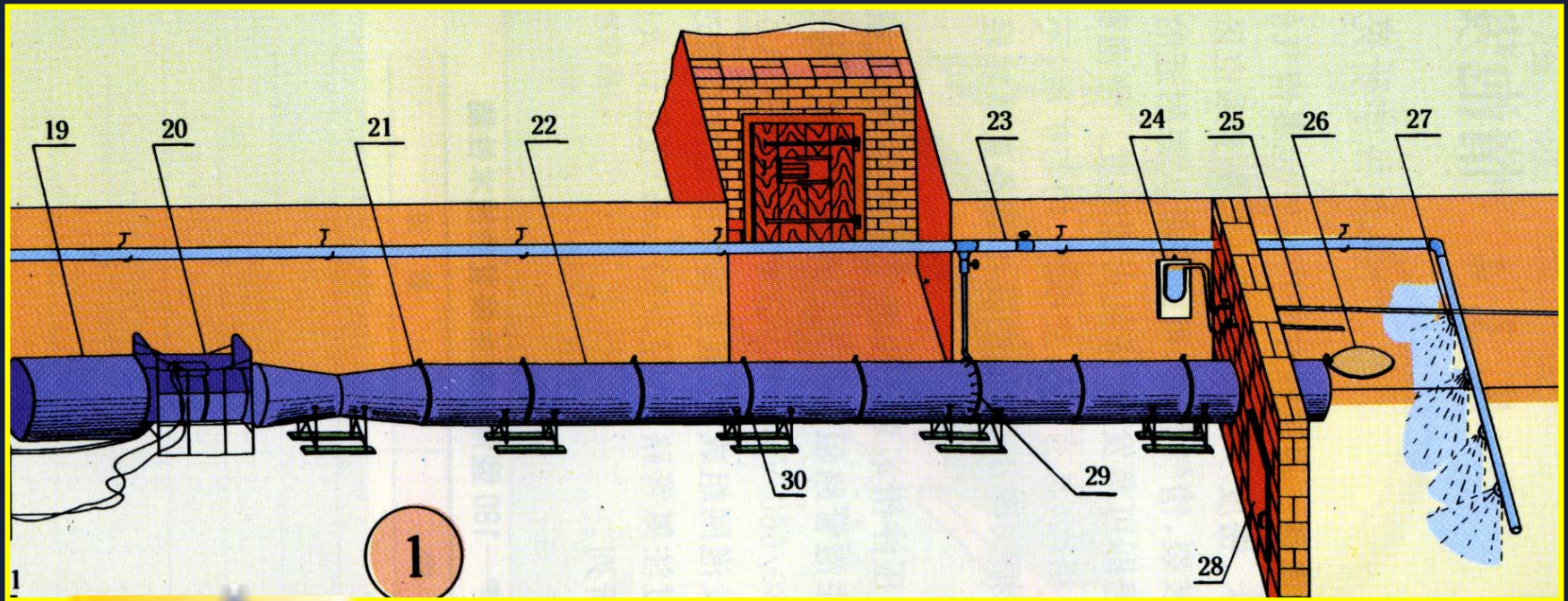

# Mine Emergency Rescue

Rescue case of gas explosion caused by fire accident.

## Design of auxiliary ventilation blower and adjusting pressure balance equipments

### 1、 Calculation of adjustment

$$\Delta h_{me} = h_f - R_{me} ( Q_t - Q )^2$$

$\Delta h_{me}$ —adjustment , Pa

$h_f$ —operation pressure of the auxiliary ventilation blower, Pa

$R_{me}$ —intake and return airway wind resistance ,  $k\mu$

$Q_t$ —airflow volume after adjustment at the working face ,  
 $m^3/min$

$Q$ —airflow volume before adjustment at the working face ,  
 $m^3/min$

# Mine Emergency Rescue

Rescue case of gas explosion caused by fire accident.

Design of auxiliary ventilation blower and adjusting pressure balance equipments

2、Deployment of auxiliary ventilation blower and adjusting pressure balance equipments

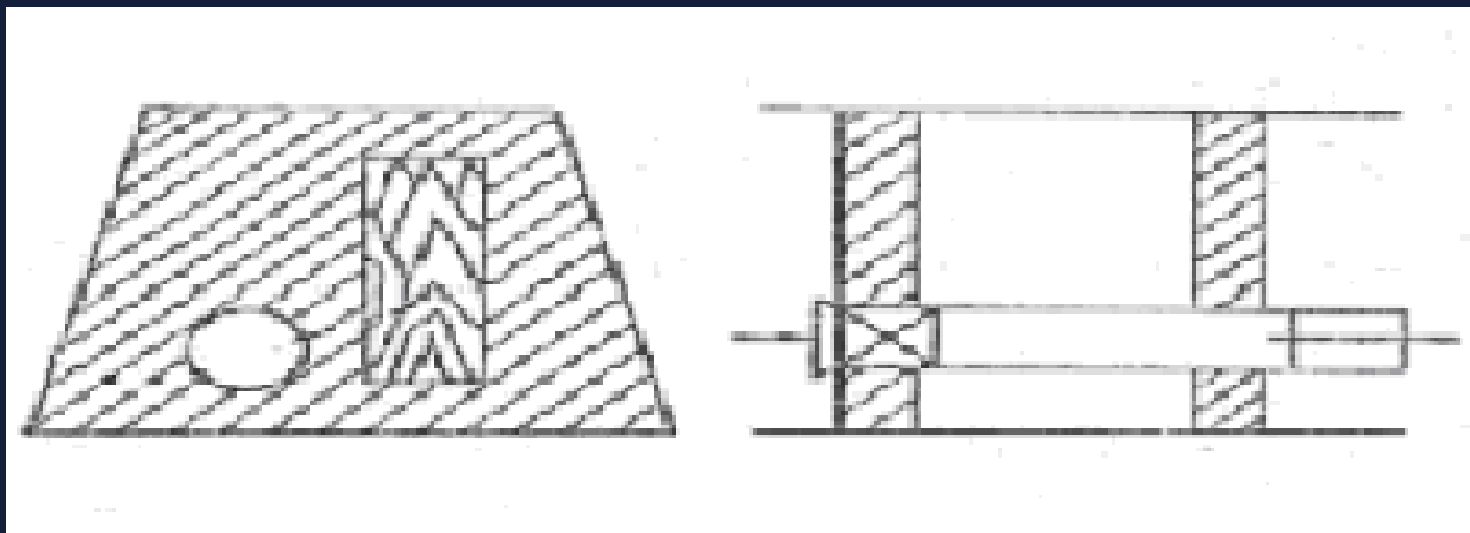

# Mine Emergency Rescue

## Rescue case of gas explosion caused by fire accident.

$$\Delta h_{me} = R_{me} (Q_1 + Q_2)^2$$

$\Delta h_{me}$ —adjustment , Pa

$R_{me}$ —wind resistance along the working face to the adjusting point ,  $k\mu$

$Q_1$ —original leaking volume ,  $m^3/min$

$Q_2$ —ventilation fan supply ,  $m^3/min$

### Case

Date : Aug 24, 1999

Place : Hanzhuang mining bureau No.2 mine, Baofeng County

Accident : gas explosion

Rescued persons : 67 persons

Saved lives : 26 persons

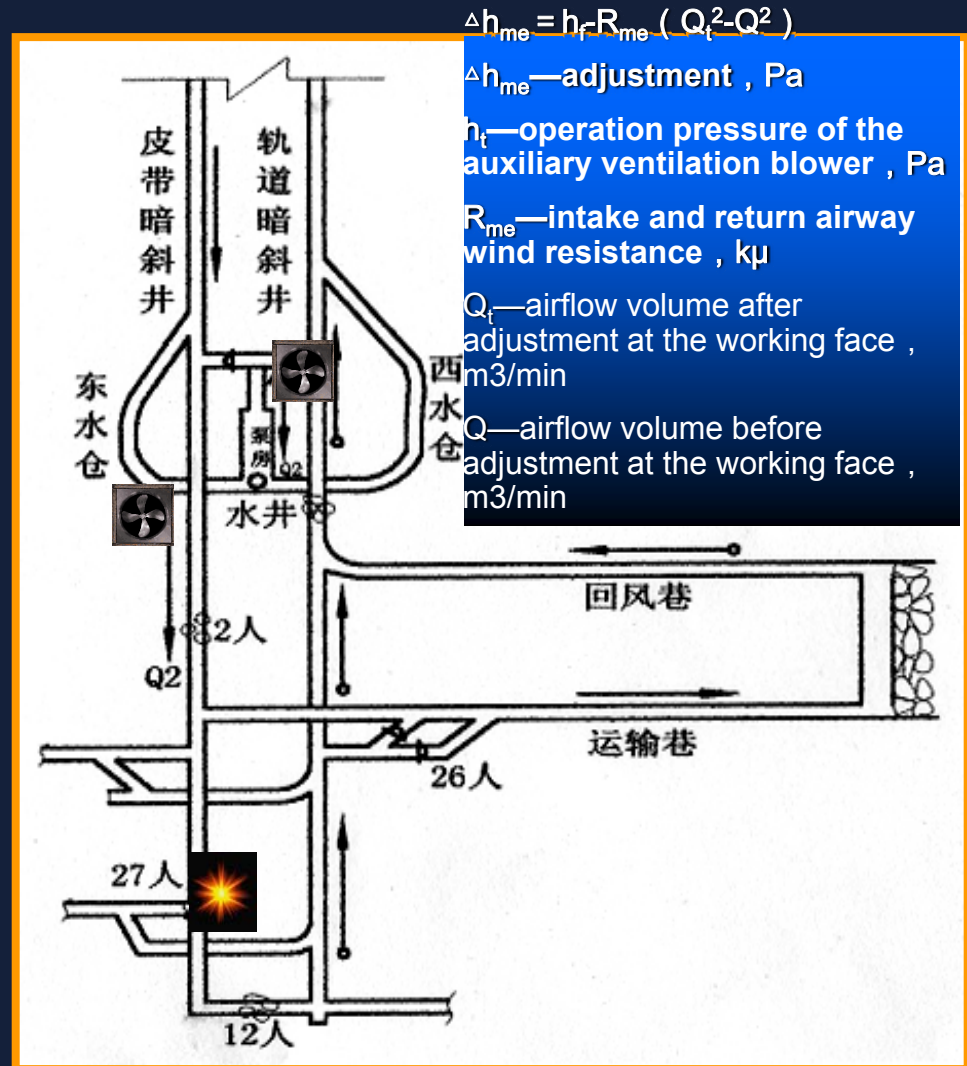

# Mine Emergency Rescue

## Flood Emergency Rescue

### (→) Analysis on living conditions of trapped workers after mine flood

When floods happen in mine, miners are often trapped in the mine and they wait for rescue at suitable place. In the course of rescue, leaders at all levels and the officers and men should fight for rescuing trapped people as soon as possible according to the “positive rescue” principle. But such occasions sometimes will occur: When trapped workers have not been rescued after a long period of time and people do not think trapped workers can be rescued alive, people will not have enough determination and confidence. Especially when outer water level is higher than the level of the working place of trapped workers, people will think trapped workers have lost living conditions, they will rescue slowly and even give up rescue, therefore bungle the rescue and make workers suffer more and even lose lives. As a result, based on technical materials and practical conditions, people should be clear about the matter by analyzing living conditions of workers who are trapped in the mine after the flood.

Living conditions and living time of trapped workers will be illustrated by analyzing air possibility and changes of air components of the place, and physiological changes of trapped staff .

# Mine Emergency Rescue

## Flood Emergency Rescue

(→) Analysis on living conditions of trapped workers after mine flood

### 1、 Analysis on air possibility of the trapped place after the flood occurring in the mine

Air is the primary condition for subsistence of trapped workers. If only there is space, there is air, people will have the possibility of living. As a result, when the flood occurs in the mine, trapped place should be analyzed scientifically and judged whether there is air on the basis of flooding conditions.

- (1)、 When the level of trapped place is higher than that of outer water, if without special conditions, trapped place is assumed definitely to have air.
- (2)、 When the level of trapped place is lower than that of outer water, it becomes complicated, it can be divided into two types according to specific conditions of mine flooding:



# Mine Emergency Rescue

## Flood Emergency Rescue

---

(←)Analysis on living conditions of trapped workers after mine flood

1、Analysis on air possibility of the trapped place after the flood occurring in the mine

a、 when flooding accident occurs in the mine, it is usually very heavy, the flood flows downwards and squeezes out the air of the lower drift and submerges the lower drift. Namely, when flooding occurs in the mine, flood can directly flow into the drift which is in the lower position of the flooding spot, no air exists.

b、 after the flooding occurring in the mine, the flood often submerges firstly the lower level drift or the lean drift, consequently, there is no space for air in these drifts. However, upper drifts which link with these drifts will not be submerged even the level of outer water is higher than upper drifts, if there is no air leaking, so there is air in drifts.



# Mine Emergency Rescue

## Flood Emergency Rescue

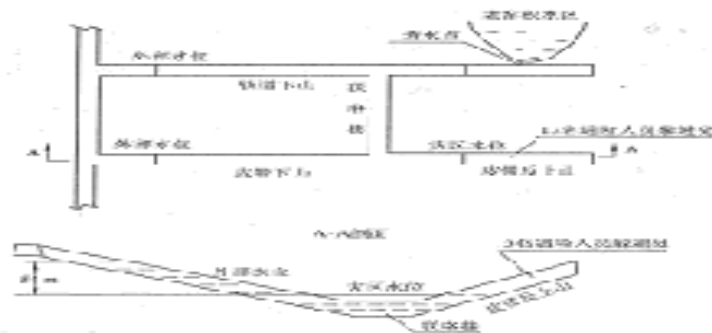

### (→) Analysis on living conditions of trapped workers after mine flood

For example : Some mine encountered old workings water-logged zone when the driving track had undergone its reverse raise, then flooding accident happened. The flood firstly submerged tracks and the level drift which is at the bottom of the belt reverse raise, which made the air of the driving head of the belt reverse raise could not leak out, therefore there was air in the driving head of the belt reverse raise. There were 13 miners trapped in this space. What's more, when the outer level is 54m higher than the level of the driving head of the reverse raise, namely, the air pressure of the trapped place is five atmospheric pressure. There was a pressed air pipe through the top of the trapped place, after the flooding, some people opened the pressed air pipe in order to supply air to the trapped place. But the air leaked out through the pressed air pipe, so the water level of the trapped place became higher. A trapped miner found this situation and closed the pressed air pipe in time, which prevented from the rise of the water level of the trapped place because of air leaking.

The rescue staff rescued trapped workers through nearly 100 hours efforts by quickening the course of draining. Because the water level rose slowly after the flooding and fell slowly in the draining, in this course human body kept balanced with inner and outer pressure, as a result out pressure did not produce great influence on human body when they were rescued.

# Mine Emergency Rescue

## Flood Emergency Rescue

(→)Analysis on living conditions of trapped workers after mine flood

### 2、 Analysis on the air quality of the trapped place of the mine

#### (1) The decrease of oxygen concentration

Factors of the decrease :

a、 Organic matter oxidation;

b、 Gas and  $\text{CO}_2$  that produced by coal and rock make the oxygen concentration in the air decline relatively;

c、 The breath of trapped workers will consume oxygen, which is the major factor of declining oxygen concentration. The trapped workers usually took some violent actions at first when they are trapped, but when they find that there is no way to get out of the dangerous area, they will take horizontal position and wait for rescue. When the oxygen concentration is lower than 10%, it threatens life.



# Mine Emergency Rescue

## Flood Emergency Rescue

(→)Analysis on living conditions of trapped workers after mine flood 2、 Analysis on the air quality of the trapped place of the mine

(2) Harms that anoxia produced to human body

Human intake oxygen every second in order to oxidize the food in the body and maintain life. Ordinary people need 0.25L oxygen every minute when they take rest, and they need 1L to 3L every minute when they work, which shows that the oxygen needs is related to intensity of labor. When the oxygen concentration of the air changes, human body will respond to it. Specific conditions are shown in the following table

Oxygen concentration/%	Human body response
16-17	No influence at rest , breathe hard at work, breath deepness increases , heart beats
14-15	Short of breath , quickened pulse , blunt response , lost of work ability, but still can maintain life.
10-12	faint , threatening life when the time is long
8-10	convulse , lose consciousness at once, stop breathing , die within several minutes , can be saved if rescued in time.

As a result, according to "Coal Mine Safety Regulations", the oxygen concentration of the intake air at face is no lower than 20%, and it is guaranteed that everyone has 4 m<sup>3</sup> fresh air every minute.

If no prevention measures are taken, miners at the bottom of the mine and rescue staff will go to blind drift that does not ventilate, consequently death accidents that result from anoxia suffocation will happen.

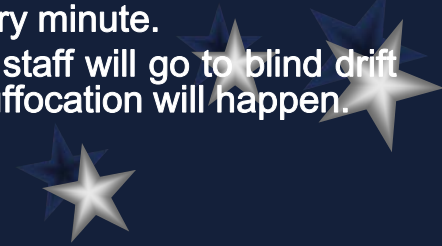

# Mine Emergency Rescue

## Flood Emergency Rescue

(→)Analysis on living conditions of trapped workers after mine flood

### 2、 Analysis on the air quality of the trapped place of the mine

#### (3) The increase of CO<sub>2</sub> concentration

a、 Factors of the increase : ( 1 ) Organic matter oxidation , oxygen consumption , release of gas such as CO<sub>2</sub>. ( 2 ) CO<sub>2</sub> that produced by coal and rock or CO<sub>2</sub> from the goaf which is pressed into the trapped place make CO<sub>2</sub> concentration of the air increase. ( 3 ) Trapped workers release CO<sub>2</sub> when they breathe, which is the major factor for the increase of CO<sub>2</sub> concentration.

#### b、 The table of human body response to CO<sub>2</sub>

CO <sub>2</sub> concentration/%	Human body response
1	Short of breath
3	respiratory rate increases , respiratory capacity increases by 2 times, fastens tiredness
5	Breathe hard , blood circulation fastens , tinnitus
10	headache , heavy breathing , very exhausted
10-20	Lose consciousness in a short period of time , faint, stop breathing
20-25	Die of choke

# Mine Emergency Rescue

## Flood Emergency Rescue

(→) Analysis on living conditions of trapped workers after mine flood

2、 Analysis on the air quality of the trapped place of the mine

(4) The increase of noxious gases. In the air of the trapped space at the bottom of the mine, if the noxious gases concentration is higher than the highest standard that "Coal Mine Safety Regulations" regulate, it will threaten to human body. When noxious gases concentration is keeping an increase state, and reach to the following index respectively: CO is as high as 0.4%, H<sub>2</sub>S is as high as 0.05%, NO<sub>2</sub> is as high as 0.025%, SO<sub>2</sub> is as high as 0.05%, trapped workers will experience life risk. In the course of analyzing the living conditions of trapped workers, whether there is noxious gases going into trapped place and the increase condition of noxious gases should be taken into consideration.

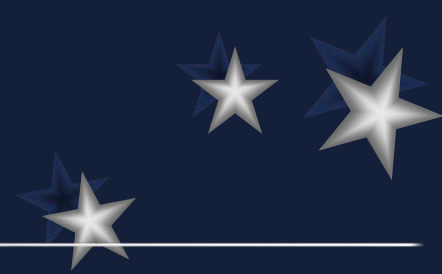

# Mine Emergency Rescue

## Flood Emergency Rescue Case

### □ Case

**Time :** May 16<sup>th</sup>, 2001

**Place :** No. 2 Mine, Yunzhenshan, Yuzhou City, Xuchang

**Disaster type :** Mine flood

**Rescued workers :** 17 persons

**Alive :** 7 persons

### Oxygen Concentration in the Drift

1、 $40\text{m} \times 8\text{m}^2 = 320\text{m}^3$

2、 $320\text{m}^3 \times 20\% = 64\text{m}^3 = 64000\text{L}$

3、3 days、7 persons' oxygen consumption =  
 $7 \text{ persons} \times 1\text{L} / \text{min} \times 1440 \text{ min} / \text{day} \times 3 \text{ days}$   
 $= 30240\text{L}$

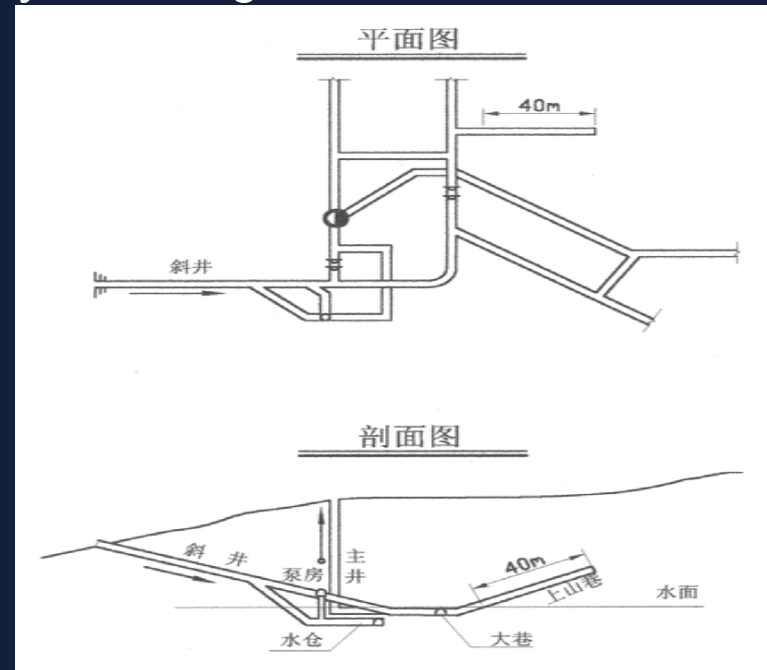

# Mine Emergency Service and Disaster Relief

## Case of Major Mine Gas Explosion

### Incidents caused by Gas Outburst

- October 20, 2004 witnessed an especially serious gas explosion caused by oversize coal-gas outburst at Daping Coal Mine of Zhengzhou Coal Industrial (Group) Co., Ltd.. The accident caused 148 people dead, 32 people injured( 5 seriously injured) and RMB 39.357 million of direct economic loss.

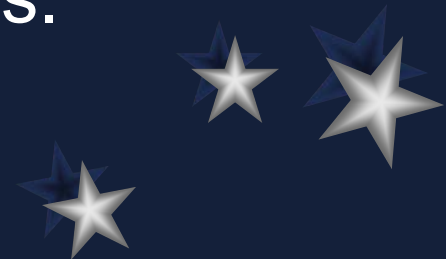

The CPC Central Committee and the State Council attach great importance to the accident. General Secretary Hu Jintao, Premier Wen Jiabao, Vice Premier Huang Ju and State Councilor Zhou Yongkang made important instructions. The State Council Working Group composed of State Councilor Hua Jianmin, deputy secretary general of the State Council You Quan and principal leaders of relevant ministries went to the accident scene to guide the emergency service, disaster relief and accident investigation. They also consoled the injured people of the accident and the rescue team members.



# 大平煤矿瓦斯爆炸区域图示

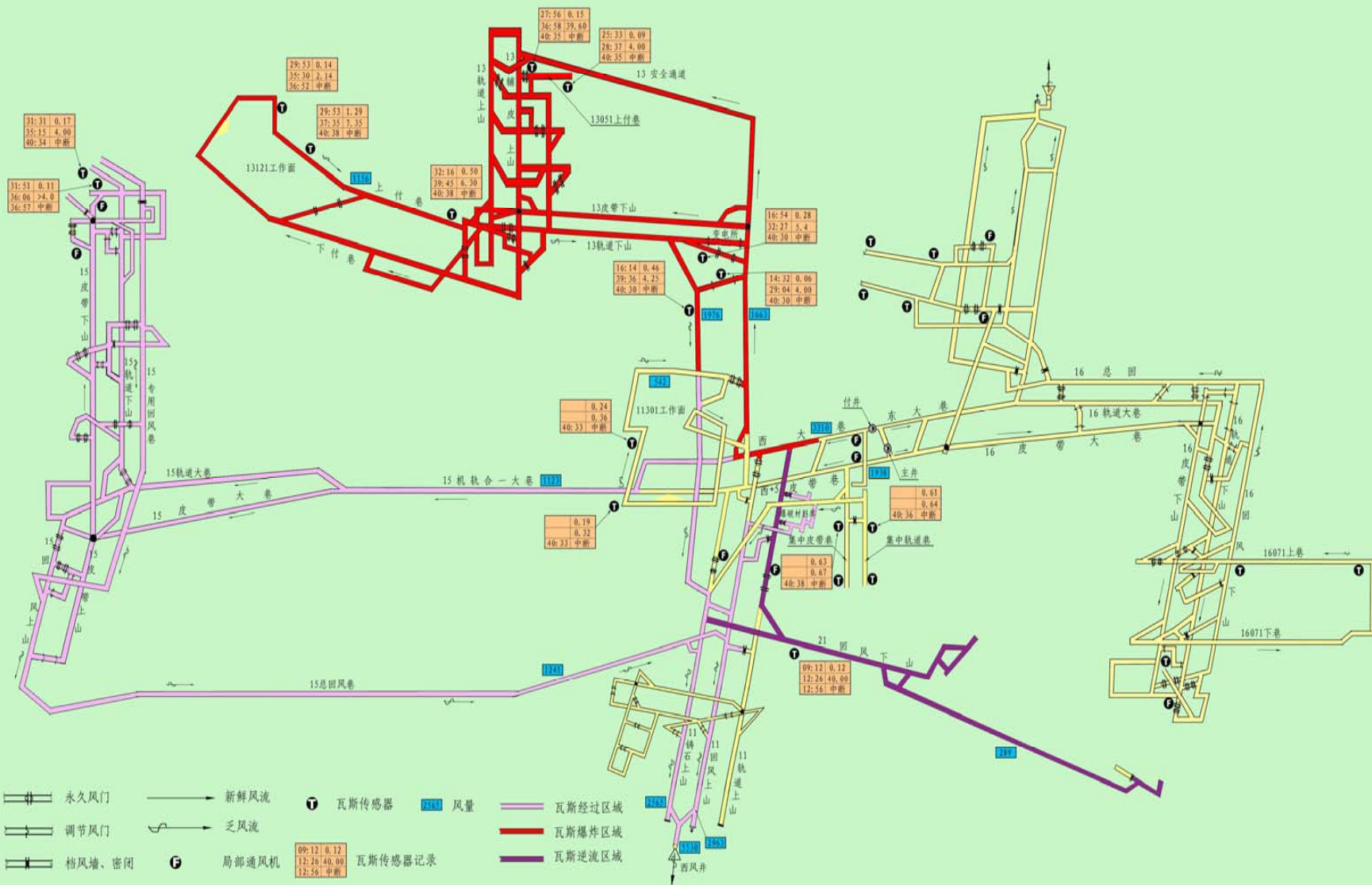

图例

- 永久风门
- 新鲜风流
- 调节风门
- 乏风流
- 挡风墙、密闭
- 局部通风机
- 瓦斯传感器
- 风量
- 瓦斯经过区域
- 瓦斯爆炸区域
- 瓦斯逆流区域
- 瓦斯传感器记录

# 大平煤矿“10.20”事故瓦斯突出及扩散过程演示

22时32分16秒~22时39分45秒，  
瓦斯浓度从0.5%升到6.3%。

21轨道下山岩石掘进  
工作面,突出煤岩量约  
1894t,瓦斯量25万m<sup>3</sup>

22时31分31秒~22时35分15秒，  
瓦斯浓度从0.17%升到4.0%。

22时09分12秒~22时12分26秒  
瓦斯浓度从0.12%升到40%以上。

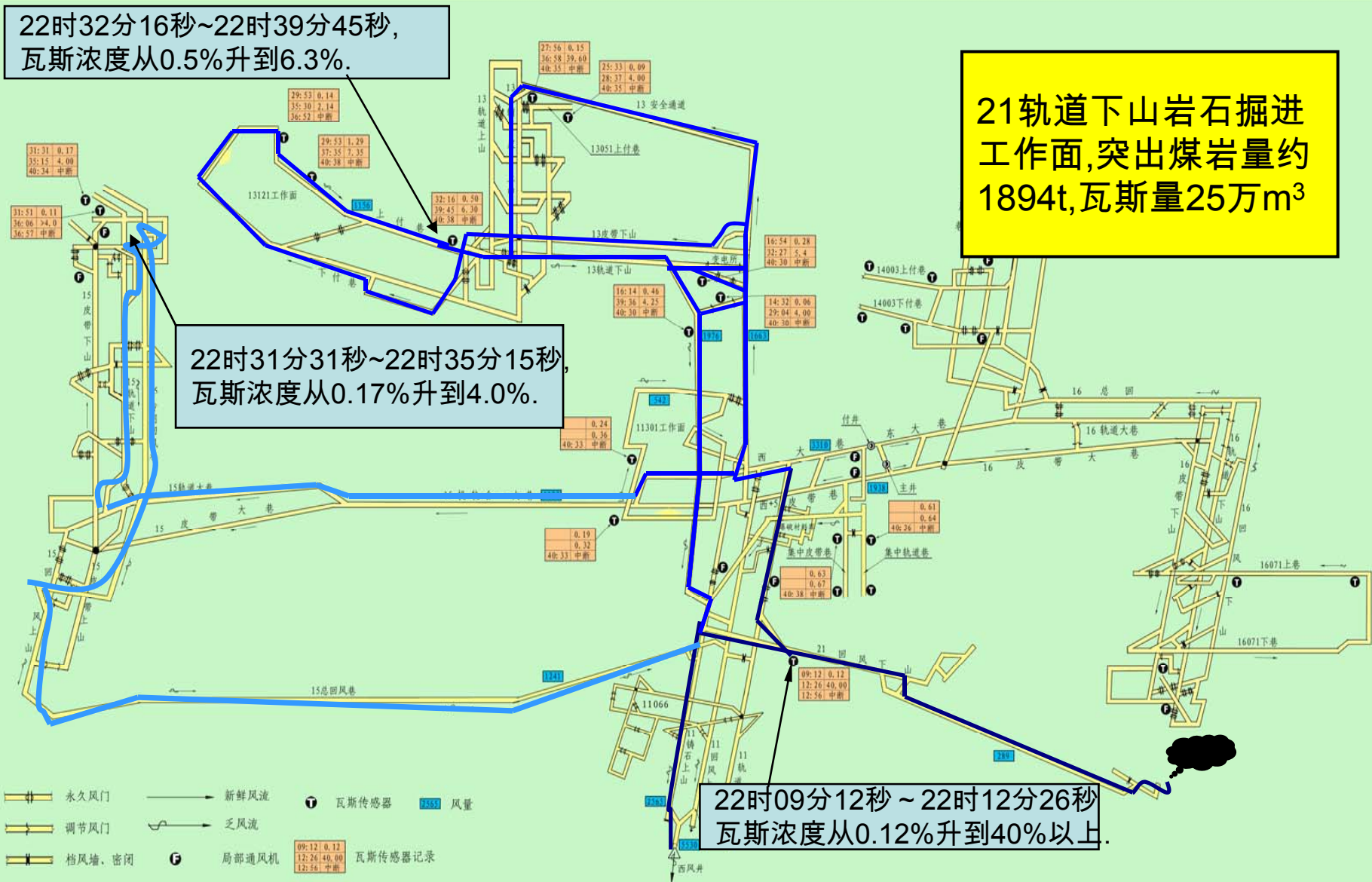

图例

- 永久风门
- 新鲜风流
- 瓦斯传感器
- 风量
- 调节风门
- 乏风流
- 局部通风机
- 瓦斯传感器记录
- 挡风墙、密闭

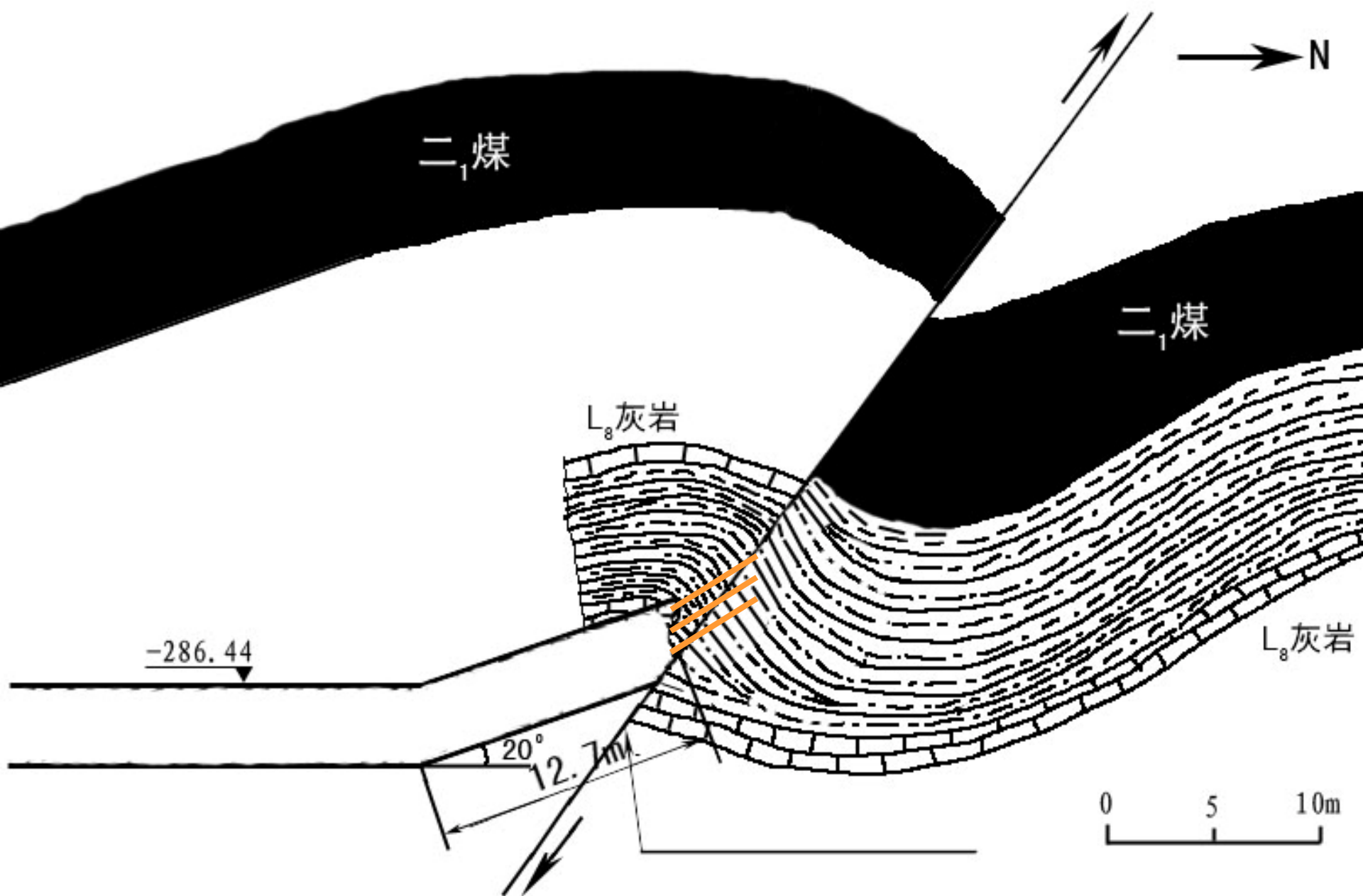

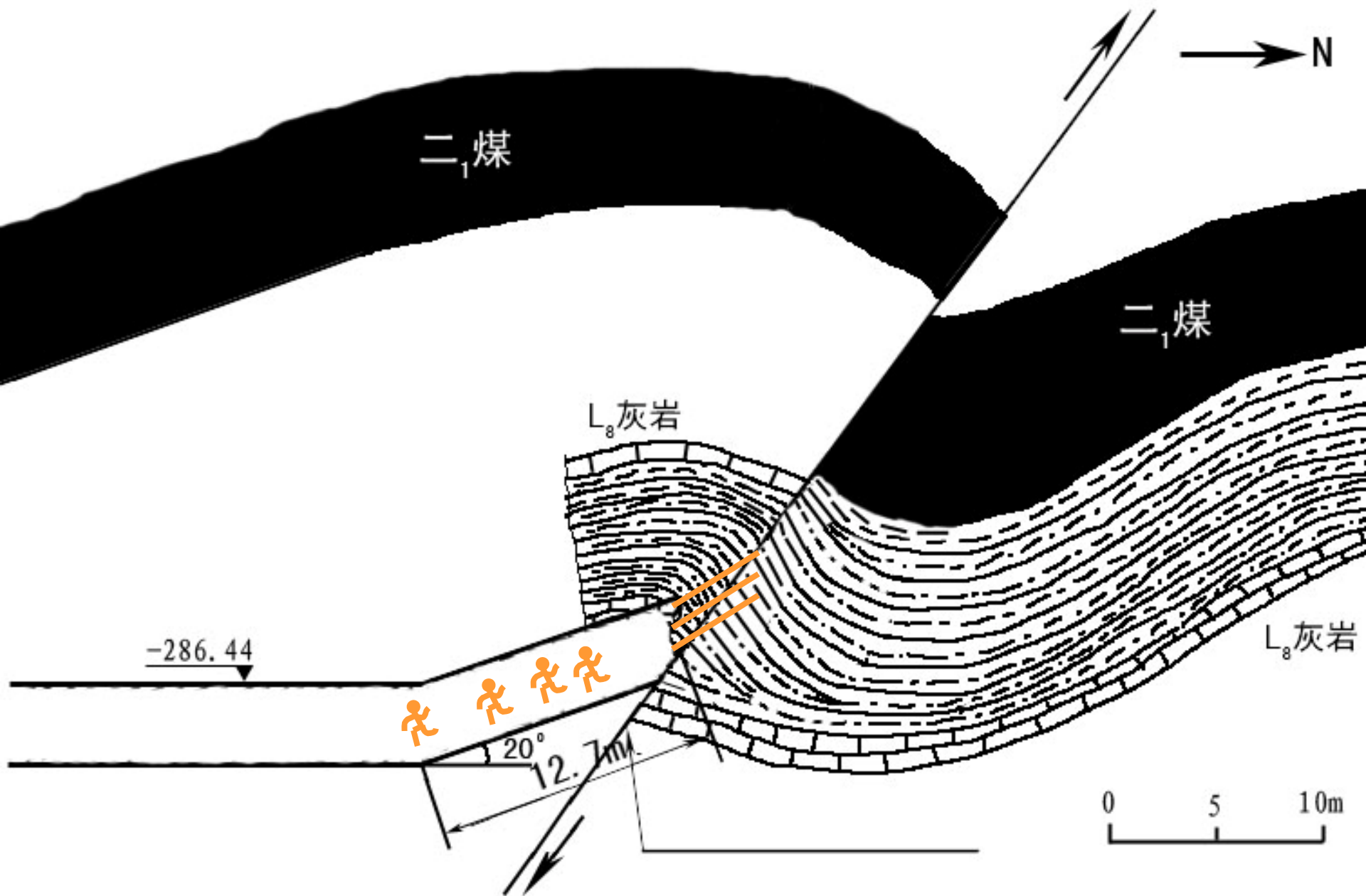

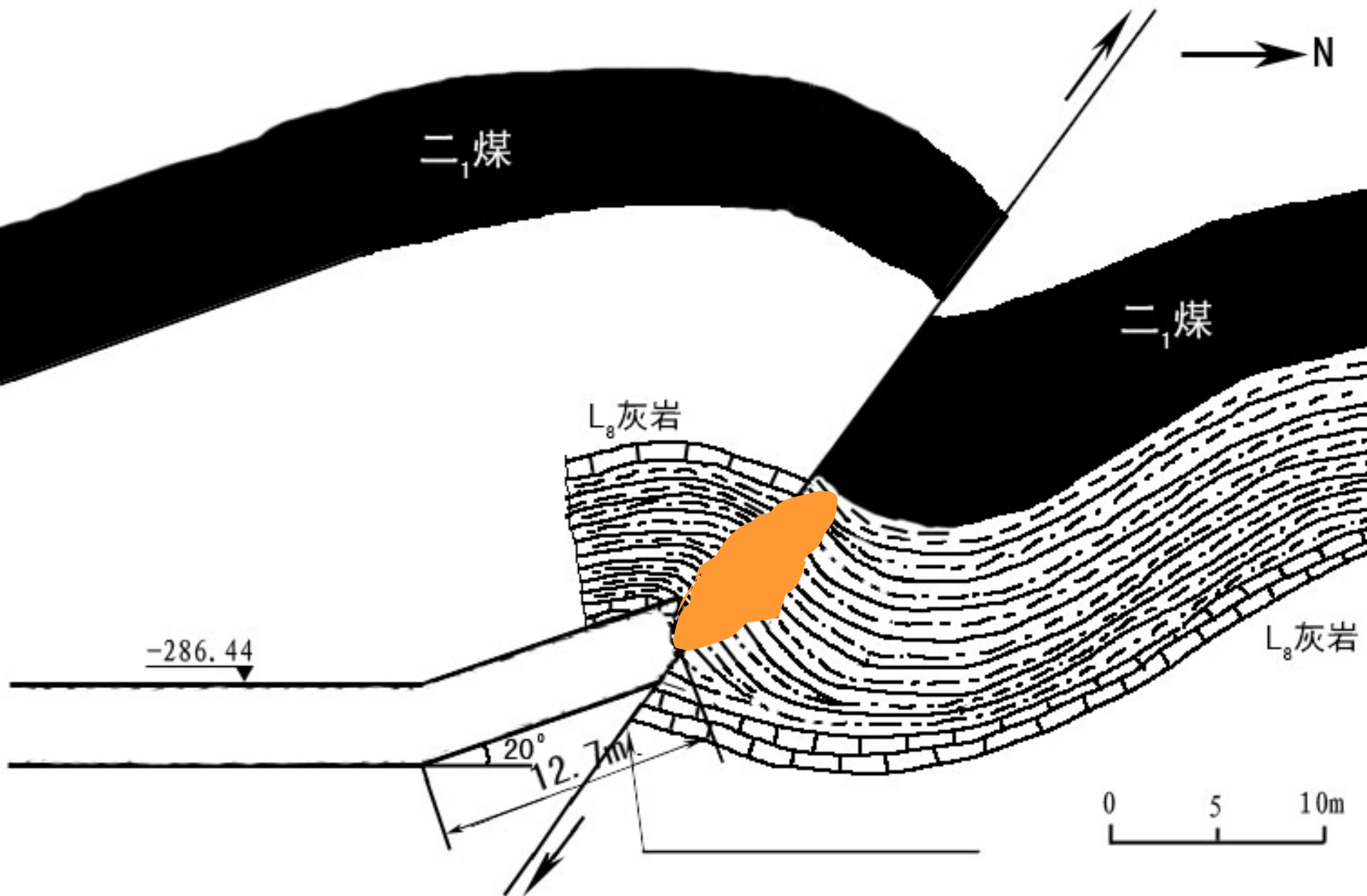

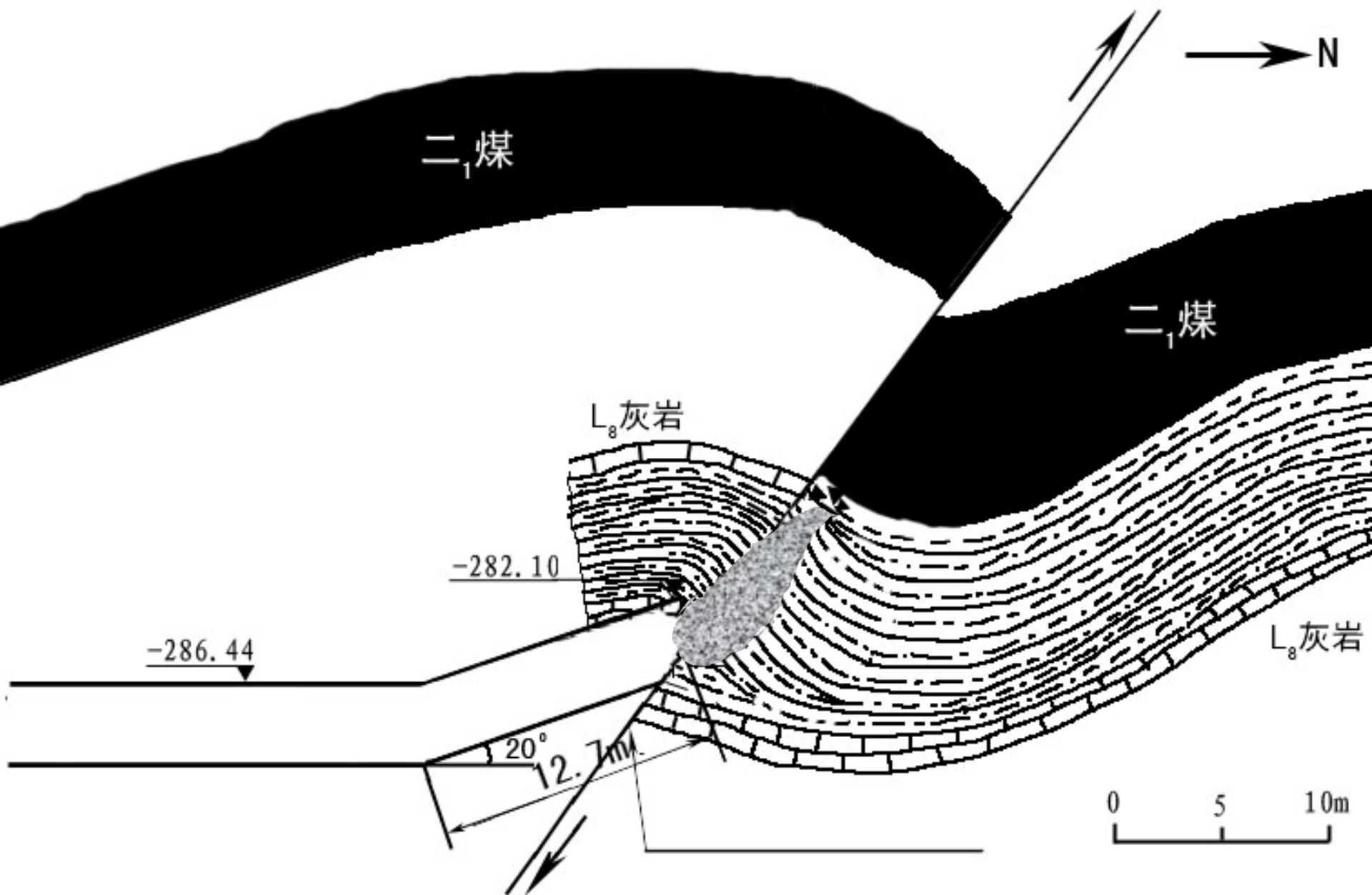

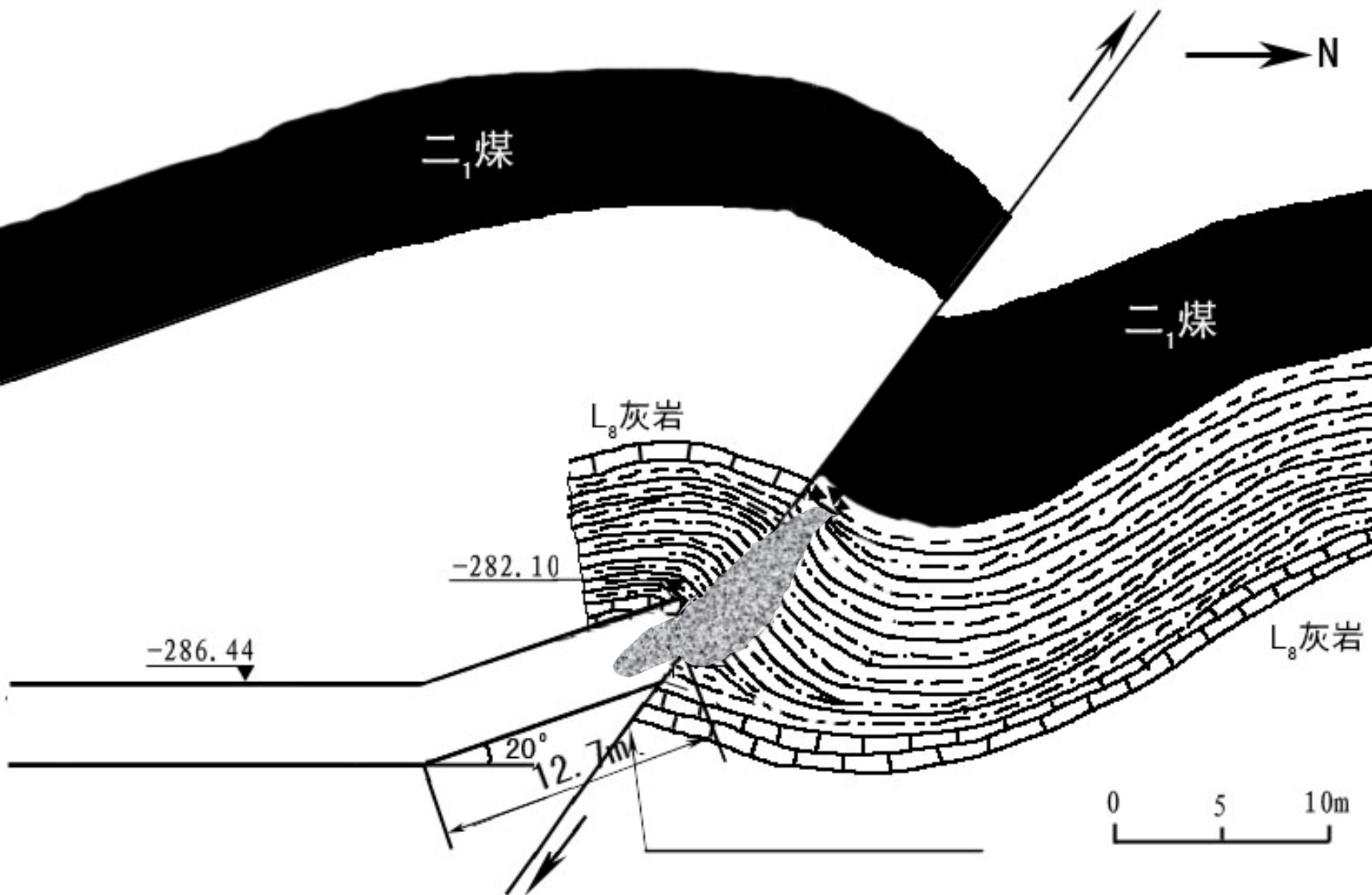

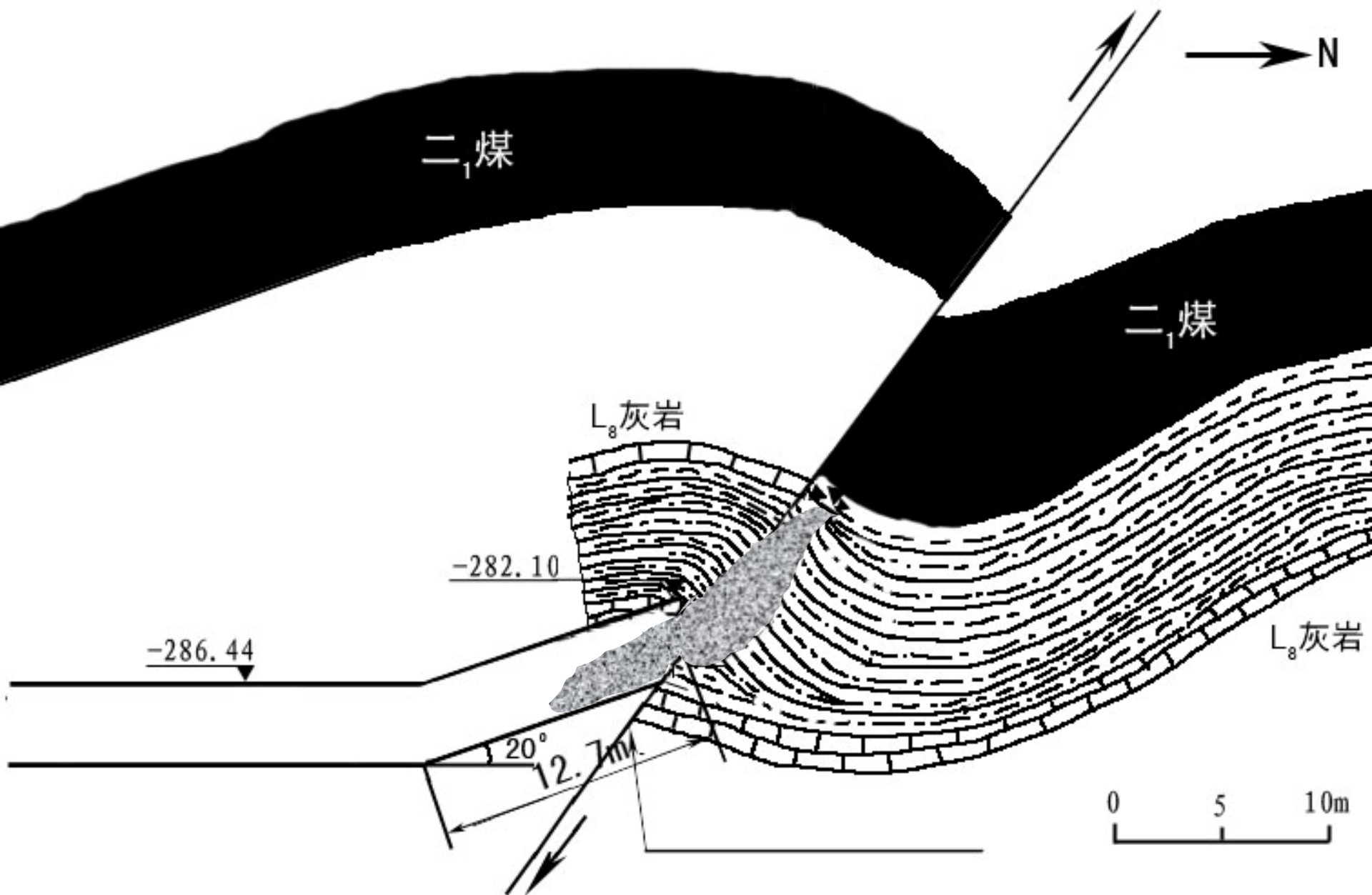

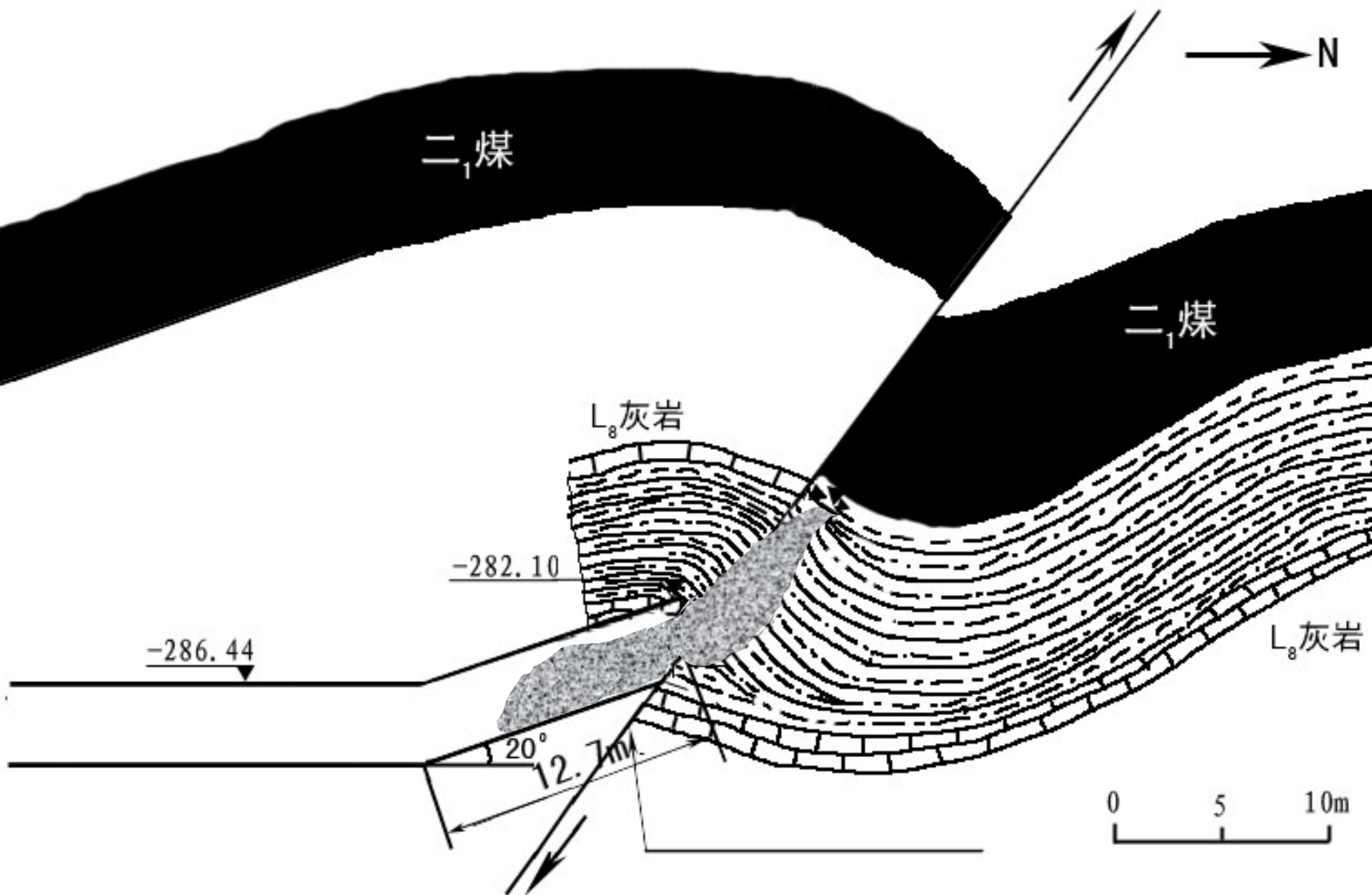

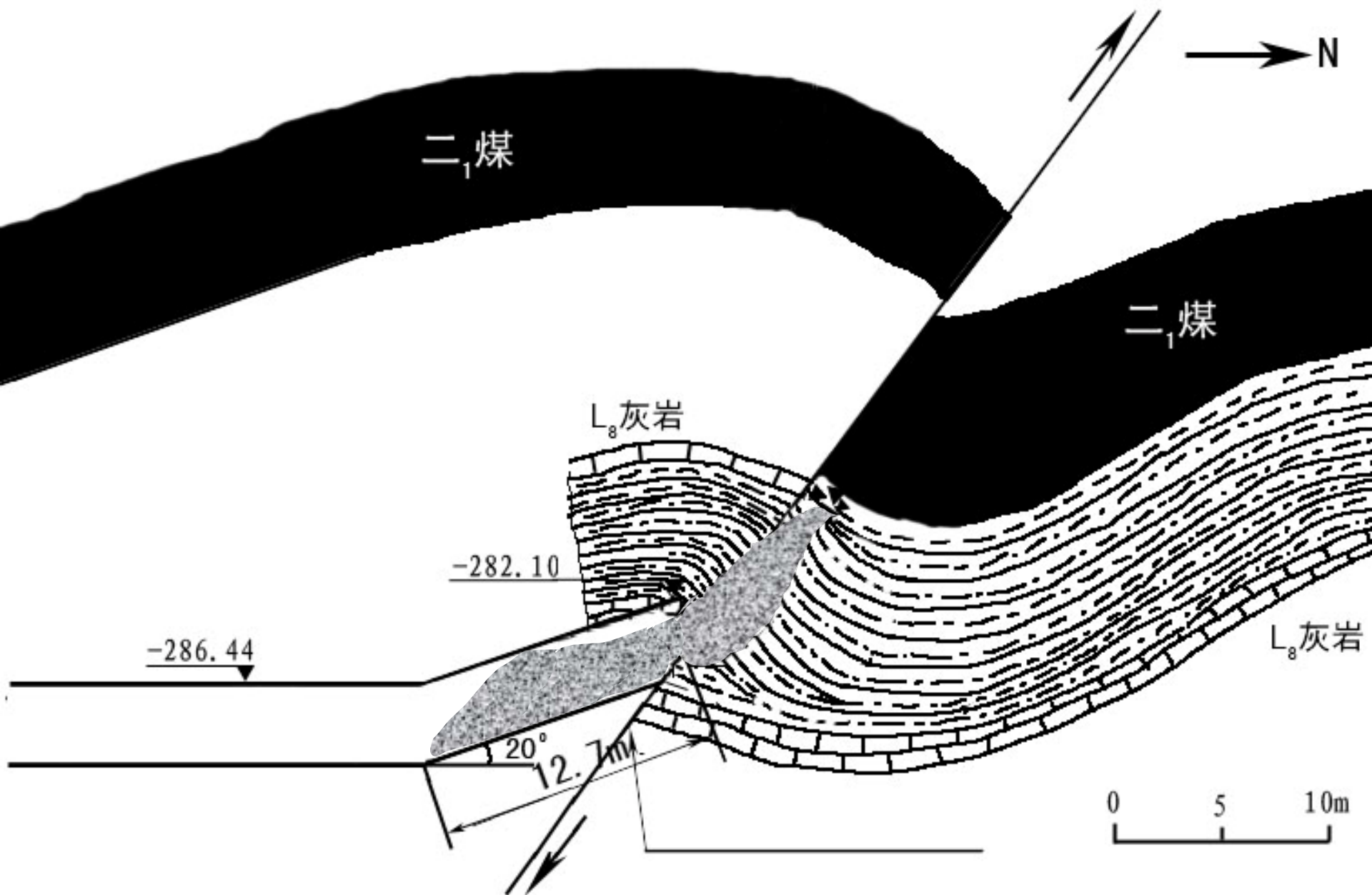

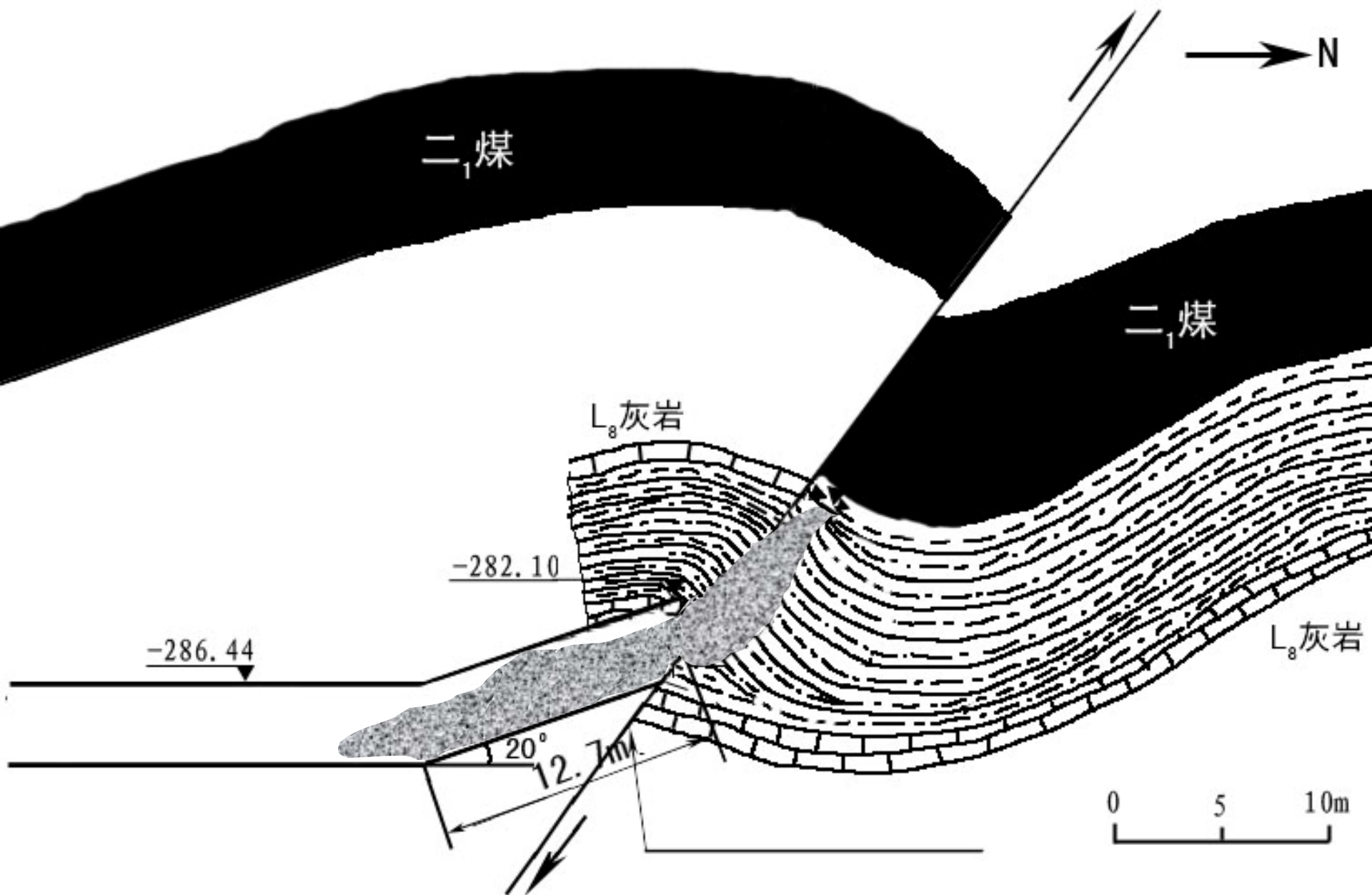

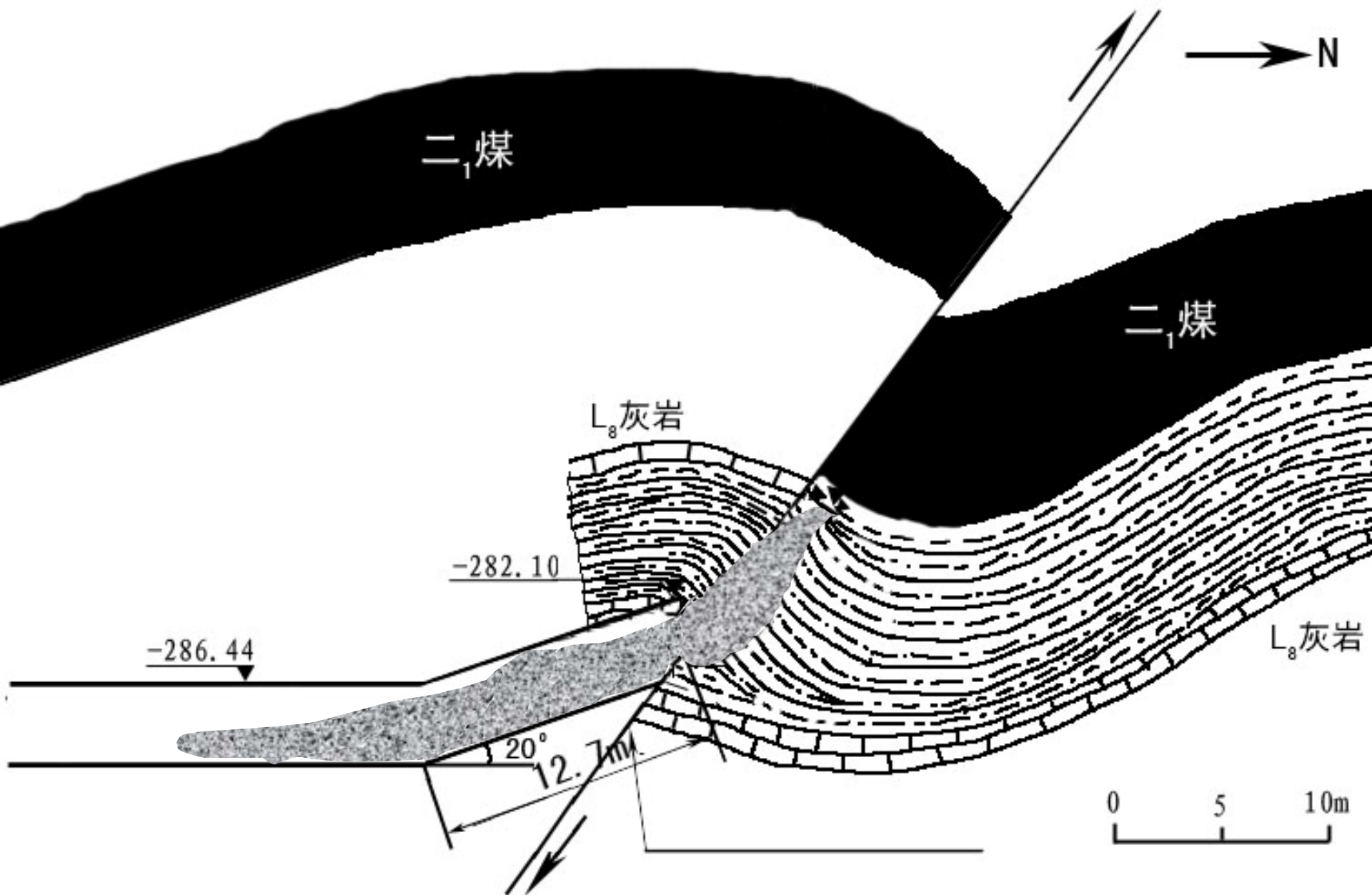

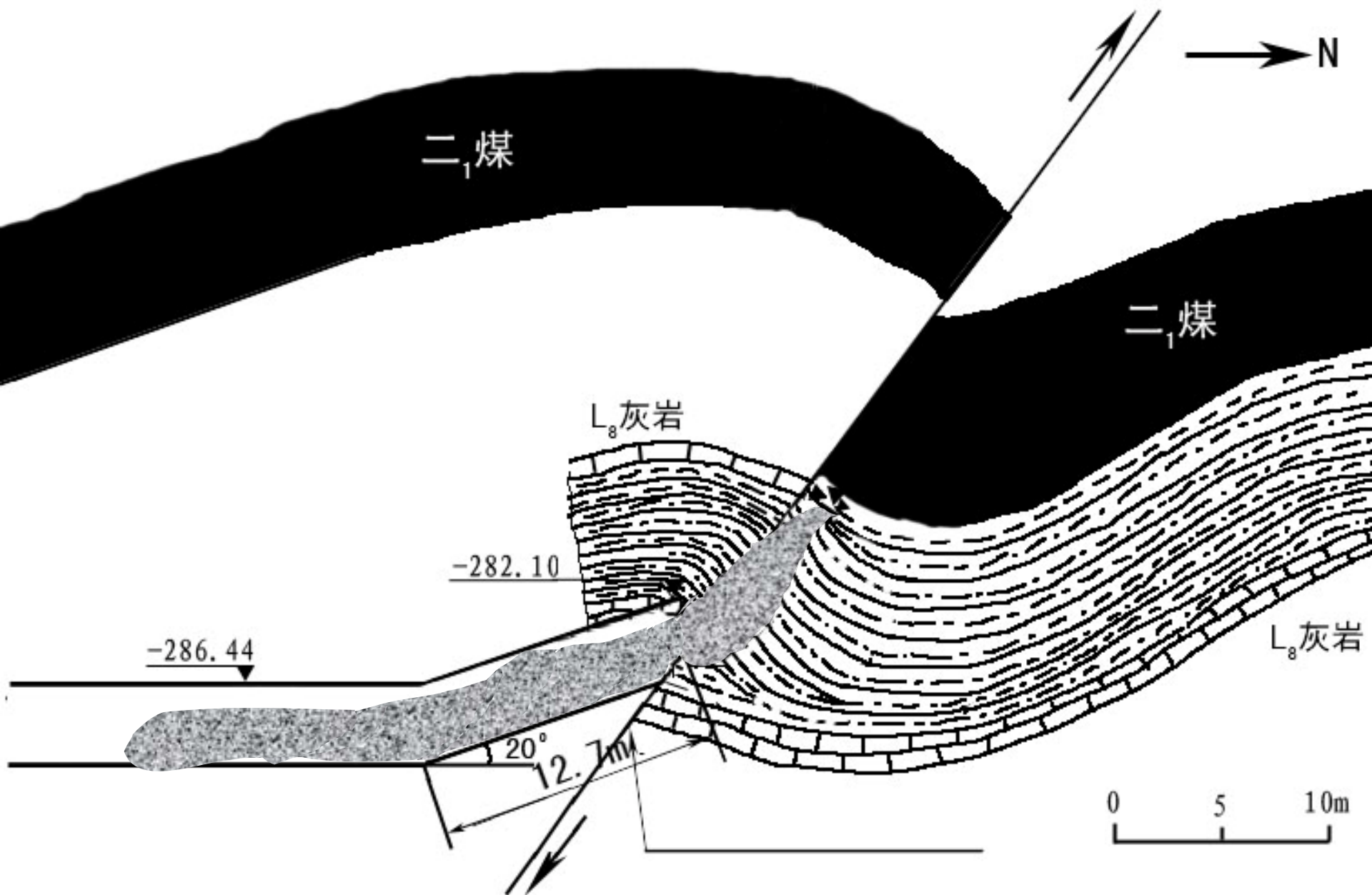

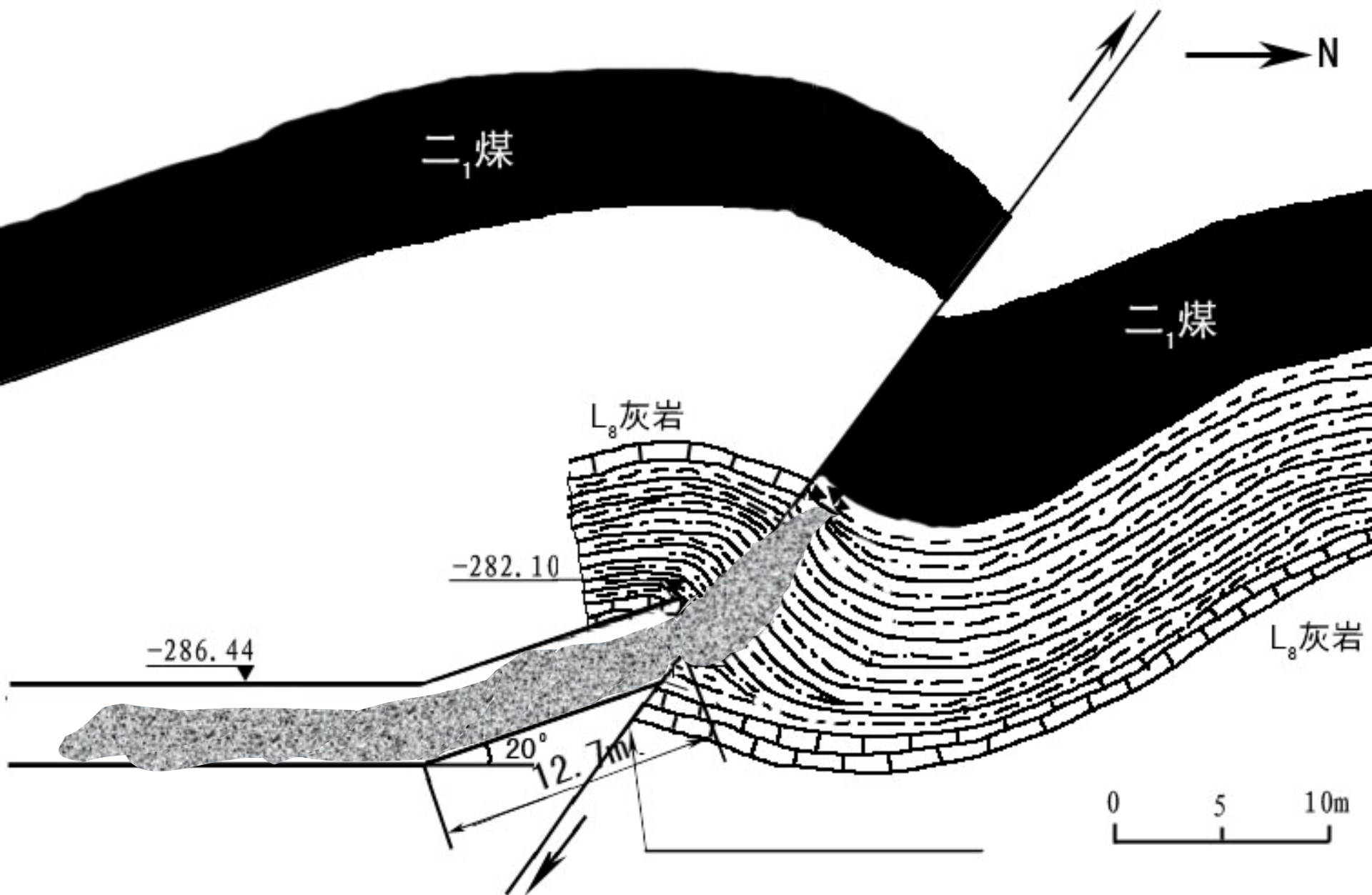

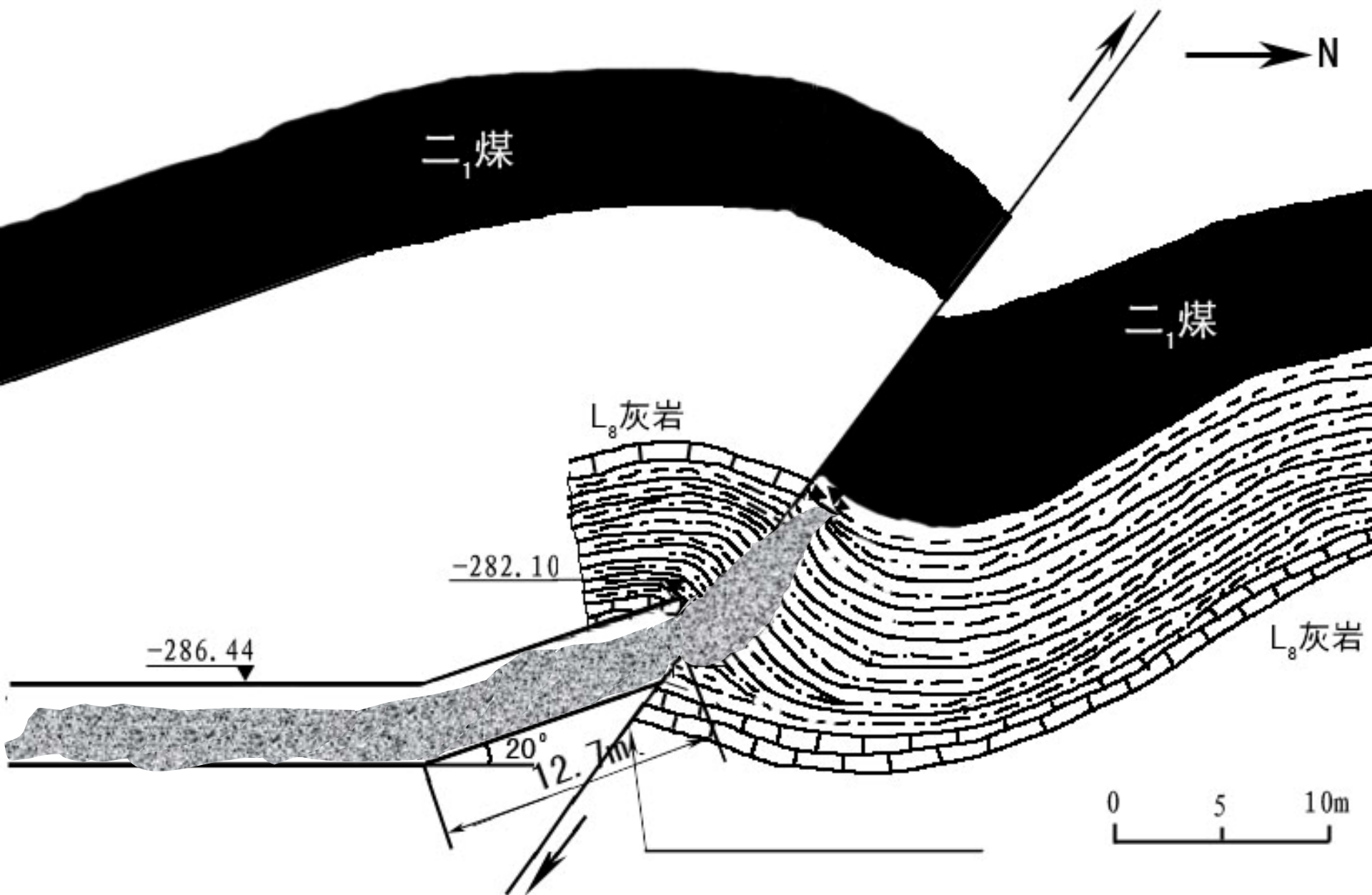

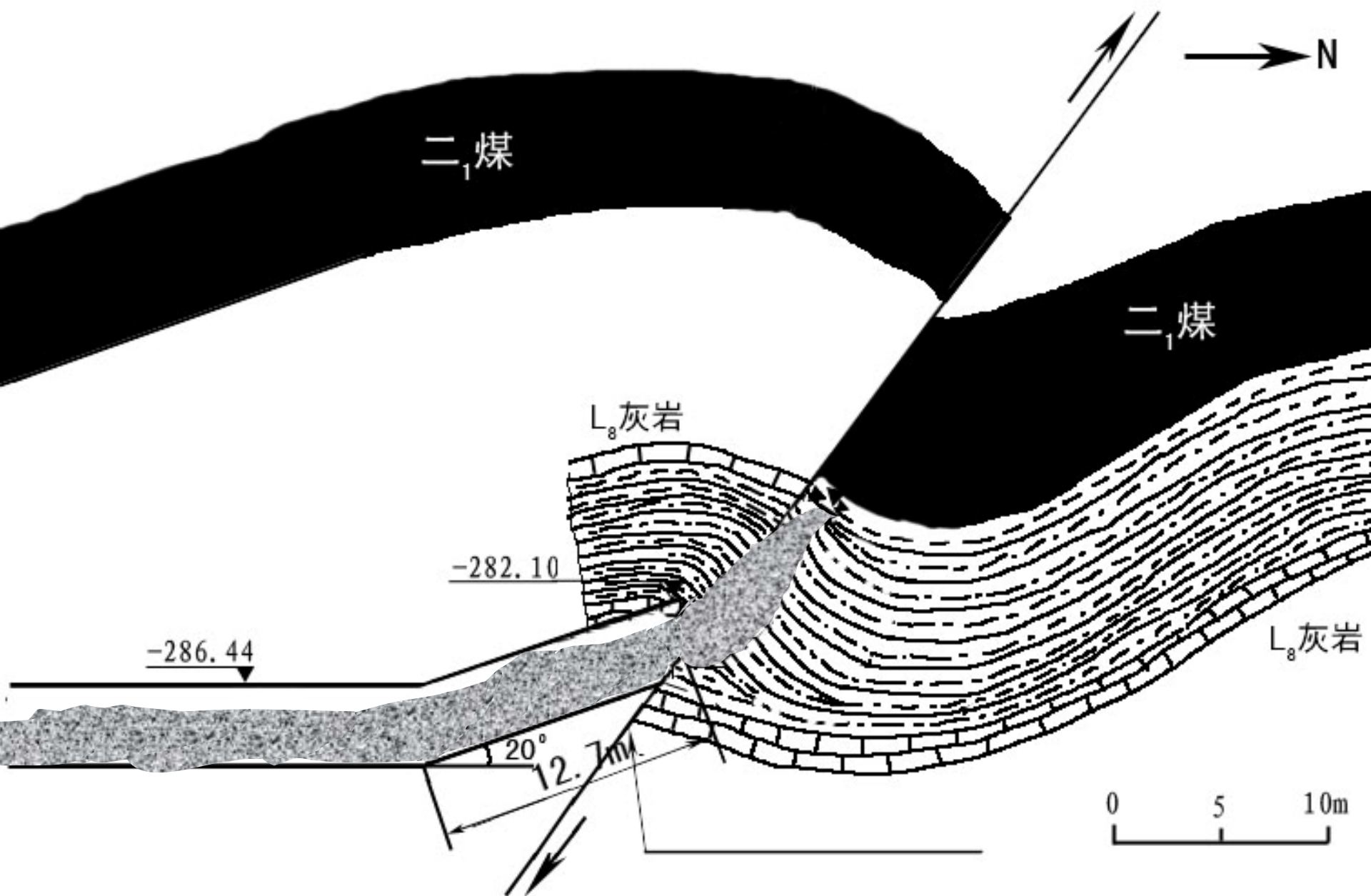



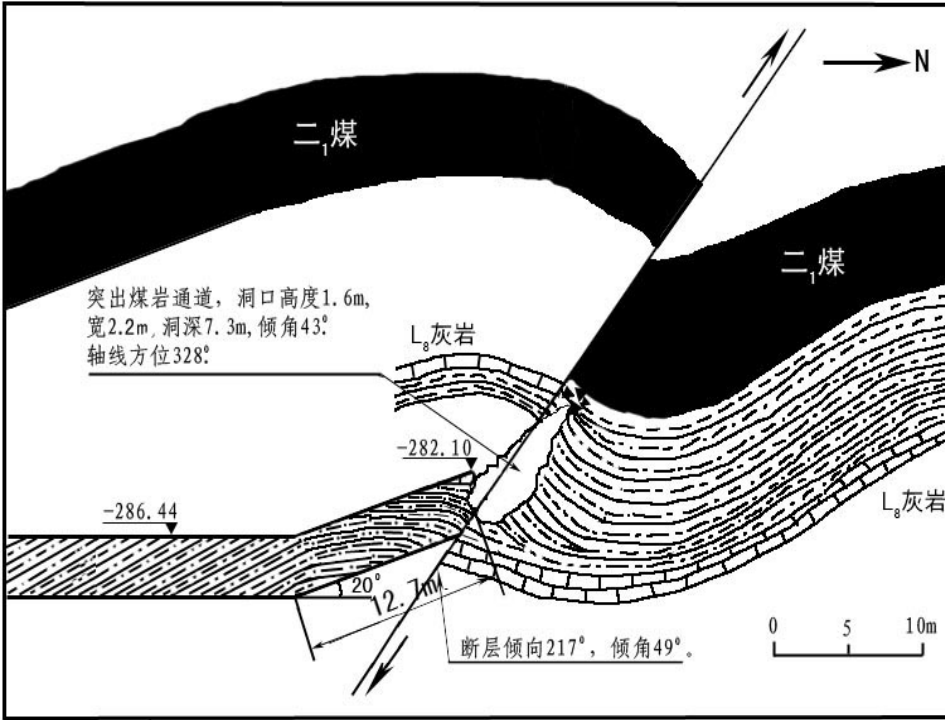

## 2 Analysis of the Accident

### *Brief Introduction of Coal (Rock) Outburst :*

- Place of Outburst

Dip rock heading face of track 21 (Elevation: -282m,  
Vertical depth below the surface: 612m)

- Time of Outburst

22:09, October 20, 2004

- Type of Outburst

Oversize coal and gas outburst

- Intensity of Outburst

Coal (rock) of outburst: about 1894 tons ,  
Gas: 250,000 m<sup>3</sup>



## 2 Analysis of the Accident

### ***Oversize Delay Outburst :***

■ Driving team were on duty. Workers responsible for blasting obtained the explosive and detonator , but none were found at the site of outburst after the accident; that is, no explosive or detonator was found during the process of cleaning coals and rocks of the outburst at the site ; expert group and technician group found the explosive box of the heading face empty when they did investigation at the site of outburst( See the photo). This demonstrated that the explosive and detonator had been used for blasting.



**Empty Explosive  
Box at the Site of  
Outburst**

## 2 Analysis of the Accident

### **Oversize Delay Outburst :**

■ The guniting team were on duty before the outburst. But according to the field investigation , there was 1-1.5m between the end of the bolting and shotcreting on the surface in the excavation roadway( see the bolt in the photo) and the hole of outburst and no bolting and shotcreting in the new rock wall, which demonstrated that this was the footage of blasting.

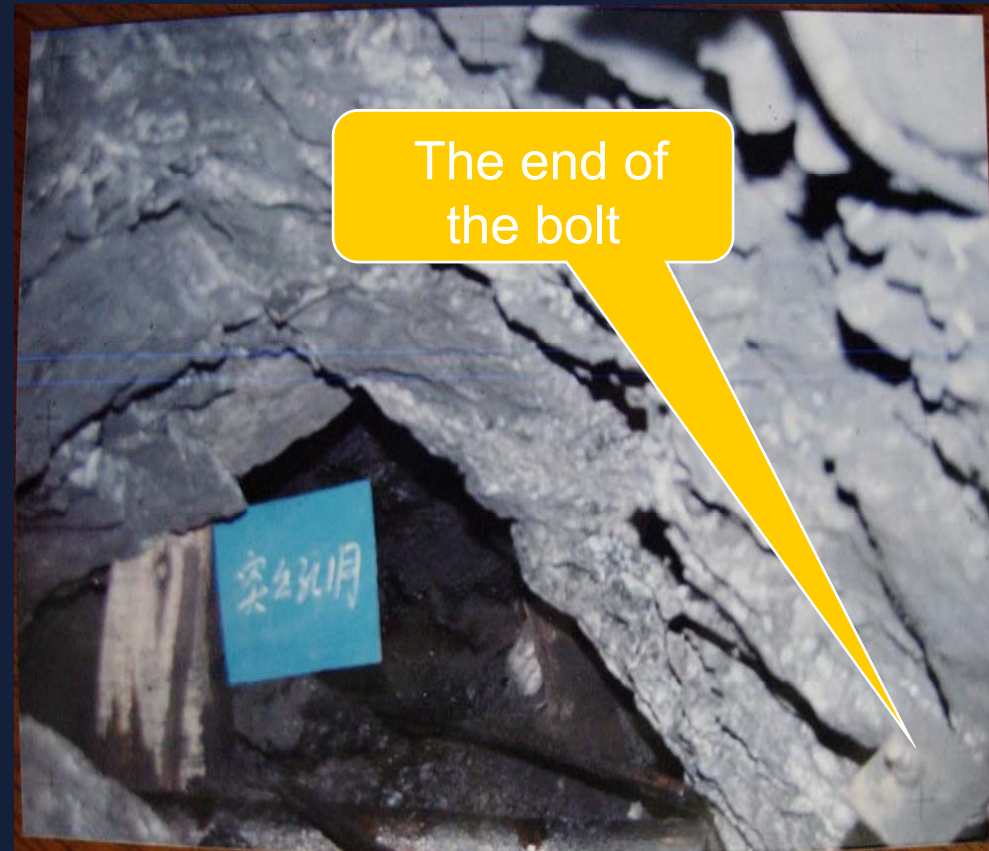

**Hole of the outburst  
and the end of the  
bolt**



## ***Oversize Delay Outburst :***

- Fu Zhongyi, who was on duty at the upper yard smelled a terrible smell(smell of the explosive smoking) before the high concentration gas of the outburst came.
- Three people died 421m away from the middle yard, each with an exploder and a roll of blasting bus under the body. This indicates that the worker responsible for blasting had put down the explosive, escaped the smoking and drew back the blasting bus before the outburst. The outburst happened during the process of worker withdrawal; that is, there was an interval between blasting and outburst.





## *Reasons for Coal and Gas Outburst:*

- The vertical depth of the place of outburst reached 612m;
- The vertical formation stress reached about 15MPa;
- According to the estimation, the gas pressure in coal seam might be over 2MPa;
- Coal was soft, and the coefficient of coal rigidity( $f$ ) was only 0.12;
- The initial speed of methane diffusion coal is fast;  $\Delta P$  was 31;
- Damage types of coal were type IV and V.

## *Reasons for Coal and Gas Outburst:*

- Dip rock heading face of track 21 was situated at the deep part of the underground mine; the blasting went through the thrust fault with complex geographic structure.
- Daping coal mine is high gas mine, but did not pay enough attention to the increasing gas rank along with the increasing depth of mine exploitation.
- The gas geology forecast work was inefficient. The thrust fault at the dip rock heading face of track 21 was not anticipated in time.
- Coal and gas outburst is a complex mining gas dynamic phenomenon. So far the law of coal and gas outburst under different geological and mining conditions has not been completely mastered.

## 2 Analysis of the Accident

### *Brief Introduction of the Gas Explosion :*

- Time of the Gas Explosion

22:40 October 20,2004

- (Fire) Origin of the Gas Explosion

Within the West Roadway near the junction of the West Roadway and cross-cut of track 11.

- Extension Area of the Gas Explosion

Intake air system of the west wing of the underground mine; mining district 13, 15, 11 and 21; return air system of the west wing of the underground mine



# 大平煤矿“10.20”瓦斯爆炸传播过程演示

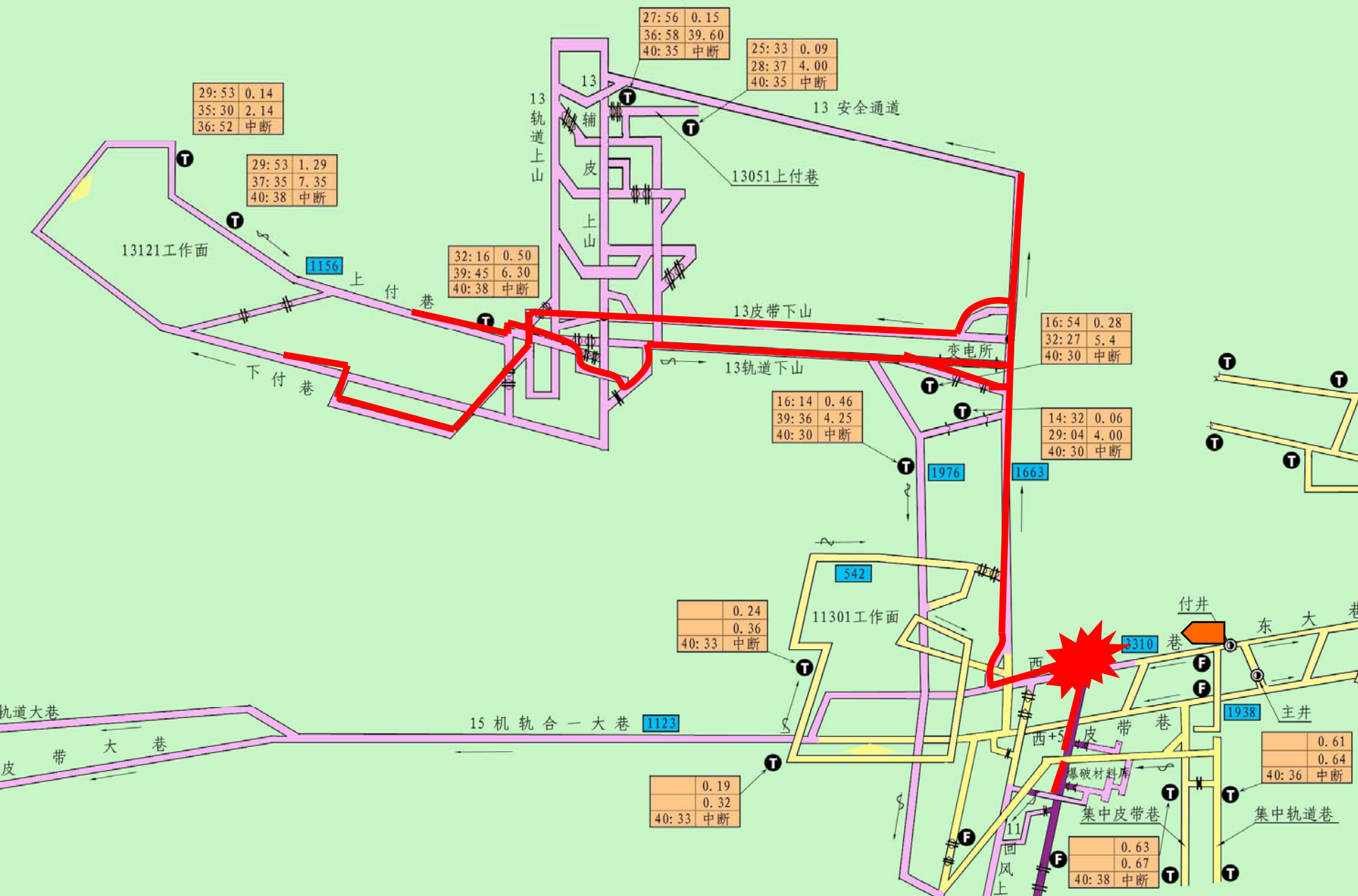



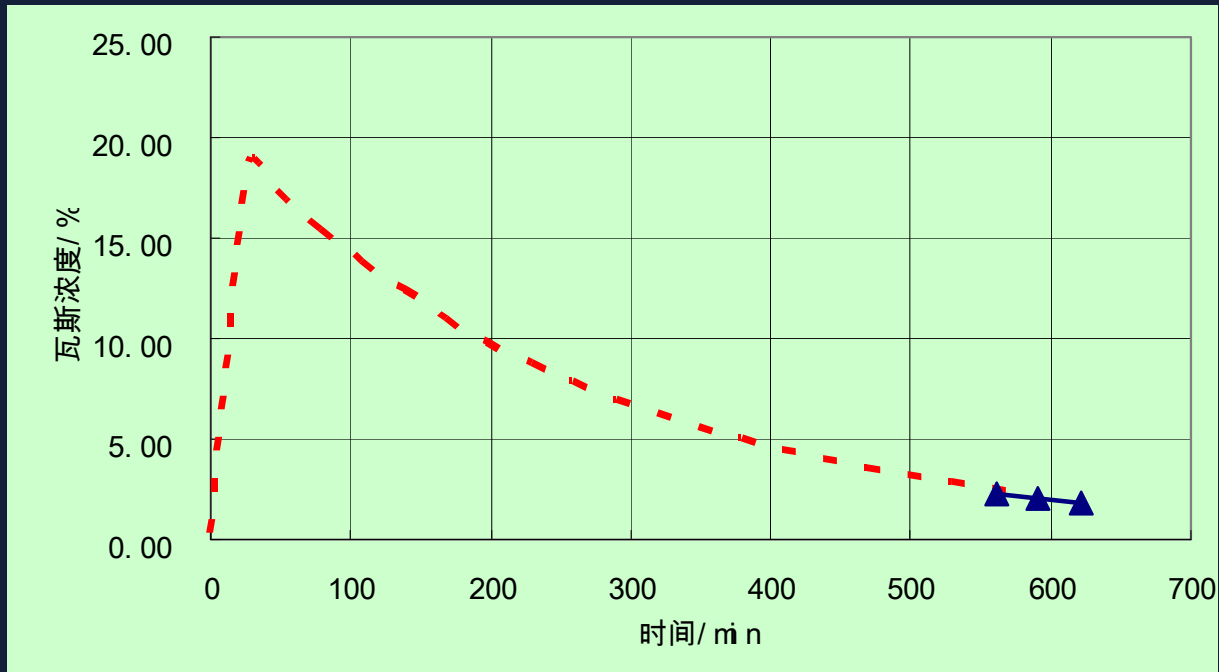
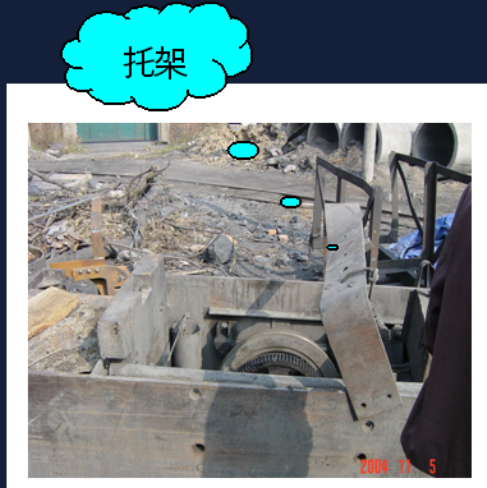

## 2 Analysis of the Accident

### *Reasons for the Gas Explosion :*

- The management of local ventilation system was confused; the 21 dip rock air-return crosshead was piled up with deposit; the air stopping with ventilation hole strengthened the burst gas adverse current; the density of the adverse gas in the fresh air in the West Roadway reached explosive level; the electric spark produced by the pantograph of trolley locomotive and the wire caused the gas explosion.
- There was a 31-minute interval between gas outburst and gas explosion; however, the emergency measures taken were not appropriate, and the power supply of the extension area of the gas was not cut off according to the emergency plan for accidents.
- Technology management and safety responsibility were not implemented; the priority went to production rather than safety.



## 2 Analysis of the Accident

### *The Nature of the Accident :*

An extremely serious responsibility accident of gas explosion caused by coal and gas outburst

### 3 Major Lessons

- 1 ) Daping coal mine witnessed several gas dynamic phenomena at the elevation of +45~-70m(that is vertical depth of 250~320m below the surface); mine gas rank was high gas mine.

Before the accident the dip rock heading face of track 21 reached the elevation of -212m( that is vertical depth of 612m below the surface), where the gas pressure and crustal stress that caused the outburst increased significantly, and the outburst hazard had changed a lot; however, people's cognition and management did not follow up in time.

The mine should be upgraded to outburst mine in time. The rules related to the prevention and control of coal and gas outburst in the *Safety Rules in Coal Mines* and *Detailed Regulations on Prevention and Control of Coal and Gas Outburst* must be strictly implemented.

### 3 Major Lessons

- 2 ) In the course of the driving at the top of the outburst coal seam and in the soleplate rock drift, people must prove up and validate geological data in advance and be clear about construction process, wall rocks, gas and geological construction and make the geological forecast. According to this forecast, deal well with the prevention from drilling through the outburst coal seam or do the outburst prevention design and construction of the faultage fracture zone of the outburst coal seam.
- 3 ) To strengthen the ventilation management, people shouldn't set up controlled air facilities and pile materials in the return air side of the working face so as to ensure that the return air in the working face is free. To strengthen the management of ventilation facilities-damper and others. In the crossheading of downcast air drift and return air drift that will be used, interlocked track-2 right damper and track-2 reversal damper must be set up, and they should be guaranteed that they can be opened and closed normally.

# 3 Major Lessons

- 4 ) Safety monitoring system centre shift should be set up in the control centre of the mine production system, which can make production disposition deal with the safety hidden dangers shown by the safety monitoring system in time. When the large-area gas exceeding limits occur in the mine, electricity must be cut off and people must be retreated at once in order to prevent the occurrence of gas accident.
- 5 ) In the main haulageway of high gassy mine and coal and gas outburst mine, mine explosion-proof special battery electric locomotive and mine explosion-proof diesel locomotive should be used.
- 6 ) To improve the quality of cadres and employees with great efforts, especially that of safety production disposition and safety production commanders, they must master professional safety knowledge and have the ability of dealing with emergency in order to avoid the occurrence and expansion of accidents.

Thank you